



## Mounting Instructions

smartServo BL 4000-C

**Important!**  
**Read thoroughly before use!**  
**Retain for future reference!**

**> Contact**

Motor Power Company S.r.l.  
Via Leonardo Da Vinci, 4  
42024 Castelnovo Sotto - Reggio Emilia  
Italy

Tel +39 0522 682710  
Fax +39 0522 683552  
Email: [info@motorpowerco.it](mailto:info@motorpowerco.it)  
<https://www.motorpowerco.com>

Manufacturer:  
Metronix Meßgeräte und Elektronik GmbH,  
Kocherstraße 3, 38120 Braunschweig, Germany

**> Revision Information**

Manual title	Mounting Instructions "smartServo BL 4000-C"
Version	1.0
Year	2023

# Table of Contents

<b>1 About this Mounting Instructions</b>	<b>5</b>
1.1 Explanations and notation	5
1.1.1 Structure of the warning notes	5
1.1.2 Structure of notes	6
1.2 Additional documents	6
1.3 Order numbers	6
1.4 Applicable standards	7
<b>2 For your own safety</b>	<b>8</b>
2.1 General information	8
2.2 Intended use	9
2.3 Target group	9
2.4 General safety instructions	10
2.5 Personal protective equipment	11
2.6 Safety notes for installation and maintenance	11
2.7 Protection against contact with electrical parts	13
2.8 Protection against electric shock by way of protective extra-low voltage (PELV)	14
2.9 Protection against dangerous movements	14
2.10 Protection against contact with hot parts	15
2.11 Protection during the handling and installation of the devices	15
<b>3 Product description</b>	<b>16</b>
3.1 Type designation	16
3.2 Device view	17
3.3 Features	19
<b>4 Mounting</b>	<b>22</b>
<b>5 Electrical installation</b>	<b>24</b>
5.1 Notes concerning the safe and EMC-compliant installation	24
5.1.1 Explanations and terminology	24
5.1.2 General information about electromagnetic compatibility	24
5.1.3 Proper wiring	25
5.1.4 Operation with long motor cables	26
5.1.5 ESD protection	26
5.2 Additional requirements for the UL approval	27
5.3 Connector BL 4100-C: power supply [X9]	28
5.4 Connector BL 4300-C: power supply [X9], [X9A], [X9B]	30
5.5 Connector BL 4100-C: motor [X6]	33
5.6 Connector BL 4300-C: motor [X6], [X6A]	36
5.7 Connector: resolvers/analogue Hall encoders [X2A]	39
5.8 Connector: encoder [X2B]	41
5.9 Connector: USB [X19]	45
5.10 Connector: standard Ethernet [X18]	46
5.11 Connector: real-time Ethernet [X21]	47
5.12 Connector: CAN bus [X4]	48
5.13 Connector: I/O interface [X1]	50

---

5.14 Connector: STO [X3] .....	52
<b>6 Technical data .....</b>	<b>54</b>
6.1 General technical data .....	54
6.2 BL 4100-C: Power supply [X9] .....	56
6.3 BL 4300-C: Power supply [X9], [X9A], [X9B] .....	57
6.4 BL 4100-C: Motor connector [X6] .....	58
6.5 BL 4300-C: Motor connector [X6], [X6A] .....	61
6.6 Resolver connector [X2A] .....	63
6.7 Encoder connector [X2B] .....	64
6.8 USB [X19] .....	67
6.9 Standard Ethernet [X18] .....	67
6.10 Realtime-Ethernet [X21] .....	67
6.11 CAN bus [X4] .....	67
6.12 I/O Interface [X1] .....	68
6.12.1 Time response of the digital inputs .....	70
6.12.2 Time response of the digital outputs .....	71
6.12.3 Time response during power ON .....	72
6.13 STO [X3] .....	73
6.13.1 Electrical data of the STO function .....	73
6.13.2 Time response .....	74
6.13.2.1 Time response of the STO activation during operation with a restart .....	74
6.13.2.2 Time response of the SS1 activation during operation with a restart .....	76
6.14 MicroSD card .....	77
<b>7 Storage/transport .....</b>	<b>78</b>
<b>8 Maintenance, cleaning, repair and disposal .....</b>	<b>79</b>
<b>9 Appendix .....</b>	<b>80</b>
9.1 CE conformity (EMC, RoHS, Low Voltage Directive) .....	80
9.2 CE conformity (Machinery Directive) .....	82
9.3 cULus certification .....	86

# 1 About this Mounting Instructions

The purpose of these Mounting Instructions is to ensure the safe installation and proper wiring of the servo drives of the smartServo BL 4000-C series. The safe use of the servo drive and of the MPC ServoCommander parameterisation program is described in the Product manual smartServo BL 4000-C.

The safety instructions and warnings in this Mounting Instructions must always be followed.

## 1.1 Explanations and notation

### 1.1.1 Structure of the warning notes

Warning notes have the following structure:

- Signal word
- Type of hazard
- Measures to prevent the hazard

#### > Signal words

##### **▲ DANGER**

Indicates an imminent hazard.

If the situation is not avoided, extremely serious and possibly fatal injuries will result.

##### **▲ WARNING**

Indicates a potentially hazardous situation.

If the situation is not avoided, extremely serious and possibly fatal injuries may result.

##### **▲ CAUTION**



Indicates a potentially hazardous situation.

If the situation is not avoided, slight or minor injuries may result.

##### **NOTICE**

Warns against damage to property.

#### > Warning signs as per ISO 7010

Warning sign	Explanation
	Warning against fatal electric voltage.
	Warning against hot surfaces.

## 1.1.2 Structure of notes

The notes in this Mounting Instructions have the following structure:

- Signal word "NOTE"
- Introductory phrase
- Explanations and special tips

## 1.2 Additional documents

Further information can be found on our homepage.

## 1.3 Order numbers

Order number	Description
9222-4102-1000	BL 4102-C
9222-4104-1000	BL 4104-C
9222-4210-00	BL 4100-C connector set

Order number	Description
9222-4304-1000	BL 4304-C
9222-4308-1000	BL 4308-C
9222-4312-1000	BL 4312-C
9222-4310-00	BL 4300-C connector set

## 1.4 Applicable standards

Standard	Description
EN 13849-1:2015	Safety of machinery - Safety-related parts of control systems - Part 1: General principles for design
EN 50581	Technical documentation for the assessment of electrical and electronic products with respect to the restriction of hazardous substances
EN 60204-1	Safety of machinery - Electrical equipment of machines - Part 1: General requirements
EN 61800-3	Adjustable speed electrical power drive systems - Part 3: EMC requirements and specific test methods
EN 61800-5-1	Adjustable speed electrical power drive systems - Part 5-1: Safety requirements - Electrical, thermal and energy
EN 61800-5-2	Adjustable speed electrical power drive systems - Part 5-2: Safety requirements - Functional
EN 62061	Safety of machinery - Functional safety of safety-related electrical, electronic and programmable electronic control systems
EN ISO 12100	Safety of machinery - General principles for design - Risk assessment and risk reduction
IEC 61508 Teil 1-7	Functional safety of electrical/electronic/programmable electronic safety-related systems
IEC 82079-1	Preparation of instructions for use - Structuring, content and presentation - Part 1: General principles and detailed requirements
UL 61800-5-1	Standard for Adjustable Speed Electrical Power Drive Systems - Part 5-1: Safety Requirements - Electrical, Thermal and Energy
CSA C22.2 No. 274	Adjustable speed drives

## 2 For your own safety

Servo drives of the BL 4000-C series can only be used safely, if you read and comply with this document.

### 2.1 General information

The servo drive has a safe design. However, certain hazards exist in the context of certain activities. These hazards can be avoided by following the correct procedures. The correct procedures for avoiding these hazards are described in this document.

In addition to the instructions described in this document, there may be additional health and safety instructions as well as general safety instructions that you must comply with. Keep informed about all of these aspects.

Professional project planning is a prerequisite for the correct and trouble-free operation of the servo drive.

The following requirements must be fulfilled to ensure the trouble-free and safe operation of the servo drive.

- Proper and correct transport
- Proper storage
- Proper installation
- Proper project planning taking in consideration all of the potential risks, necessary protective and emergency measures and the installation
- Careful operation and proper maintenance.

Only trained and qualified personnel in accordance with section 2.3 *Target group* on page 9 are authorised to work with or on the electrical systems.

The following instructions must be read and understood prior to the initial operation of the system in order to prevent injuries and/or damage to property. The following safety instructions must be complied with at all times:

- Do not attempt to install or start the servo drive without having read all of the safety instructions in this document concerning the electrical drives and controllers. These safety instructions and all other user notes must be read prior to performing any work with the servo drive.
- If the servo drive is sold, rented out or otherwise distributed to third parties, these safety instructions must be included.
- The user must not open the servo drive for safety and warranty reasons.



## 2.2 Intended use

The electronic drive control unit (servo drive) is intended for operation in combination with electric motors in an industrial environment. The handling of the servo drive requires qualified personnel that have been trained in terms of general and, in particular, electrical safety. The intended use also includes compliance with the information and instructions in this manual.

Any use going beyond or deviating from the intended use will be considered as misuse.

### **▲ WARNING Hazards caused by misuse**

Misuse of the servo drive will lead to dangerous situations.

- Use the servo drive only under the specified ambient condition.
- Do not use the servo drive outdoors or in explosive atmospheres.
- Use suitable and qualified specialist personnel for any type of work on the servo drive.
- Always comply with the voltage ranges that are specified in section 6 *Technical data* on page 54.
- Follow all of the instructions in this manual concerning the safe use of the servo drive.

## 2.3 Target group

Over its entire service life, work on the servo drive, with the exception of its operation, may only be performed by specialist personnel and/or instructed persons who have been trained for the required tasks. The servo drive is to be operated by the user.

### **› Trained and qualified personnel**

Qualified personnel in the sense of this document are persons who are sufficiently familiar with the project, set-up, installation, commissioning and operation of the servo drive as well as with all of the warnings and precautions and who are sufficiently qualified in their field of expertise:

- They have been trained, instructed and authorised to perform the switching and earthing (grounding) of the devices/systems in line with the applicable safety standards and to label them accordingly as per the job requirements.
- The service and maintenance personnel have undergone special training in the context of ESD protection measures.
- They have been trained and instructed in line with the applicable safety standards in terms of the maintenance and use of adequate safety equipment.
- They have completed first aid training.

## 2.4 General safety instructions

### **⚠ DANGER** ⚠ **Danger to life due to electric shock!**

Non-compliance with the safety instructions will lead to a potentially fatal electric shock. The general set-up and safety rules and regulations concerning the work on power installations (e.g. DIN, VDE, EN, IEC or any other national or international rules and regulations) must be complied with.

- Safety-critical applications of the servo drive are not allowed unless specifically approved by the manufacturer.
- For information about the EMC-compliant installation, see section 5.1 *Notes concerning the safe and EMC-compliant installation* on page 24. The manufacturer of the machine or system is responsible for ensuring compliance with the limits that are specified by the applicable national rules and regulations.
- The ambient conditions that are specified in the product manual must be strictly observed.
- The technical data as well as the connection and installation conditions of the servo drive are stated in this document and must be complied with at all times.
- Refer to *General technical data* on page 54 for the protection rating and pollution degree of the servo drive. Ensure that the environment corresponds to this protection rating and pollution degree rating.
- Use only original accessories and original spare parts that have been approved by the manufacturer.
- The servo drives must be connected to the mains power supply in accordance with the country-specific regulations (EN standards, VDE rules) so that they can be disconnected from the mains power supply by way of suitable disconnectors (e.g. main switches, contactors, circuit breakers).
- Use gold contacts or contacts with a high contact pressure for switching the control contacts.
- Preventive interference suppression measures should be taken for the switchgear. This can be done, for example, by connecting RC circuits or diodes to the contactors and relays.

## 2.5 Personal protective equipment

Always use personal protective equipment during the transport, installation, start-up, cleaning, maintenance and removal of the servo drive, for example:

- **Protective gloves**  
To prevent superficial hand injuries.
- **ESD safety shoes**  
To prevent foot injuries caused by falling parts.  
To prevent electrostatic charging.
- **Protective work clothes**  
To prevent superficial injuries and soiling.
- **Protective goggles**  
To prevent eye injuries caused by dust or shards/splinters.
- **Light respiratory protection**  
To prevent the inhalation of harmful substances.

## 2.6 Safety notes for installation and maintenance

### **⚠ DANGER** ⚠ **Dangerous electrical voltage!**

Prior to performing any maintenance tasks, you need to ensure that the power supply and the external power supply of the servo drive have been disconnected and secured against reconnection and that the DC bus has discharged.

During operation and also for a very long time after the servo drive has been switched off, the corresponding connections and an external braking resistor carry dangerous DC bus voltages. Contact with these voltages may result in serious or even fatal injuries.

Make sure that the DC bus has discharged by measuring at the DC bus terminals ZK+ and ZK- or wait for the maximum discharge time. This is for the BL 4000-C **10 minutes**. In the event of a device defect, connections other than those specified here may also carry a life-threatening voltage. Under these circumstances, the discharge time must be waited for in any case.

### **⚠ WARNING** ⚠ **Risk of burns due to hot surfaces**

The servo drive and, in particular, the (external or internal) braking resistor may become hot during operation. Always wait a sufficient amount of time prior to touching these parts.

Always use suitable personal protective equipment to avoid severe burns.

### **⚠ CAUTION** **Risk of injury for unqualified personnel!**

Only personnel who are trained and qualified for working on or with electrical devices are authorised to install, maintain and repair the servo drive.

➤ **To prevent accidents, injuries and damage to property:**

Perform a risk assessment and follow all of the statutory and local safety instructions and accident prevention regulations when installing or maintaining the system.

Ensure that the AC or DC power supplies are switched off and locked prior to performing any work in the area of the machine. The deactivation of the output stages or servo drive enable signals is not a suitable means of locking. In the case of a malfunction, the drive may accidentally be put into action. This does not apply to drives with the special "Safe Torque Off" feature in accordance with EN 61800-5-2.

Electronic devices are never completely fail-safe. It is the user's responsibility to ensure that the system is brought to a safe state if the electrical device fails.

Disconnect the electric equipment from the power supply via the main switch and secure it against reconnection. Wait until the DC bus has discharged in the following cases:

- maintenance and repairs
- cleaning
- long downtimes

The standard motor holding brake that is included in the scope of supply or any other external motor holding brake that is actuated by the servo drive is not suitable for the protection of the operators if used alone!

Be particularly careful during the installation process. During the installation and also later on during the operation of the drive, ensure that no drilling chips, metal dust or installation parts (screws, nuts, cable sections) can fall into the servo drive.

Use suitable personal protective equipment during the installation.

Vertical axes must be additionally secured against falling down or lowering after the motor has been switched off, for example by way of the following:

- mechanical locking of the vertical axis,
- external braking, catching or clamping devices, or
- sufficient weight counterbalance of the axis.

Perform the start-up process with idling motors. This is to avoid mechanical damage, e.g. due to an incorrect direction of rotation.

## 2.7 Protection against contact with electrical parts

### **⚠ DANGER** ⚠ **Dangerous electrical voltage!**

In certain device constellations, the rapid discharge of the DC bus voltage of the servo drive may be rendered ineffective. In these cases, the servo drives may still carry dangerous voltage levels for a very long time after they have been switched off (residual capacitor charge).

Make sure that the DC bus has discharged by measuring at the DC bus terminals ZK+ and ZK- or wait for the maximum discharge time. This is for the BL 4000-C **10 minutes**. In the event of a device defect, connections other than those specified here may also carry a life-threatening voltage. Under these circumstances, the discharge time must be waited for in any case.

### › **To prevent accidents, injuries and damage to property:**

Follow the national accident prevention regulations (for Germany, this is DGUV regulation 3 (formerly BGV A3)).

Do not touch the electrical connections of the components when they are switched on.

Prior to accessing electrical parts carrying voltages above 50 V, disconnect the device from the mains power supply or voltage source. Secure it against reconnection.

Install the respective covers and guards against accidental contact prior to switching the device/system on. Rack-mounted devices must be protected against accidental contact by way of an enclosure, e.g. a switch cabinet.

Prior to start-up and even for brief measurements or tests, connect the protective earth conductor (ground conductor) of all of the electrical devices in accordance with the circuit diagram (see section 5 *Electrical installation* on page 24) in a fixed manner (hardwiring) to the supply network or to the earthing system on site.

Comply with the minimum copper cross-section for the protective earth conductor (ground conductor) over its entire length (see EN 61800-5-1). Otherwise, the housing may carry high voltages which can cause electric shock.

With mains-powered servo drives, the leakage current is greater than 3.5 mA due to the integrated mains filters. Therefore, two separate protective earth connection points must be hard-wired for these units.

The magnitude of the DC bus voltage must be taken into consideration during the installation process in order to ensure proper insulation and protection. Ensure proper earthing (grounding), conductor rating and protection against short circuits.

## 2.8 Protection against electric shock by way of protective extra-low voltage (PELV)

### **⚠ DANGER** ⚠ **Dangerous electrical voltage!**

There is a risk of high electrical voltage due to incorrect electrical connections.

Always follow the safety instructions stated hereinbelow.

All of the connections and terminals with voltages up to 50 V of the servo drive have protective extra-low voltage. They are protected against contact in accordance with IEC 61800-5-1 and EN 61800-5-1.

Only devices, electrical components and wires or cables with protective extra-low voltage (PELV) may be connected to connectors and terminals with voltages from 0 to 50 V.

When connecting voltages and circuits, ensure that they are securely isolated from any dangerous voltages. This isolation can be realised by way of isolation transformers, safe optocouplers or battery operation without mains power.

## 2.9 Protection against dangerous movements

### **⚠ WARNING** **Risk of injury due to dangerous movements**

Always follow the safety instructions stated hereinbelow.

Dangerous movements can be caused by the faulty actuation of the connected motors. Causes may be as follows:

- improper or faulty wiring or cabling
- errors during the operation of the components
- errors of the sensors and transducers
- defective or non-EMC-compliant components
- software errors in the superordinate control system.

These errors can occur directly after the activation of the device or after some time during the operation.

The monitoring systems in the drive components exclude any malfunction in the connected drives to the greatest possible extent. However, in view of the protection of the operators, particularly in terms of the risk of injuries and damage to property, relying solely on this measure is not recommended. Until the built-in monitoring systems become effective, faulty drive movements should always be anticipated. The extent of these faulty drive movements depends on the type of control and on the operating state.

For the reasons mentioned above, protection must be ensured by monitoring or by superordinate measures. This must be implemented by the system manufacturer based on the specific system situation and on a hazard and fault analysis. This also includes the safety rules and regulations that apply to the system. Random movements of the machine or other malfunctions may be caused by deactivating, bypassing or failing to activate the safety devices.

## 2.10 Protection against contact with hot parts

**▲ WARNING**  **Risk of burns due to hot surfaces**

The servo drive and, in particular, the (external or internal) braking resistor may become hot during operation. Always wait a sufficient amount of time prior to touching these parts. Always use suitable personal protective equipment to avoid severe burns.

## 2.11 Protection during the handling and installation of the devices

**▲ CAUTION** **Risk of injury caused by crushing, shearing, cutting or impacts**

Improper handling and installation of certain parts will cause injuries. Always follow the safety instructions stated hereinbelow.

- When installing the servo drive, ensure that it can be installed, operated and removed without any danger.
- Appropriate installation clearances must also be defined.
- Comply with the intended use of the servo drive.
- When transporting the servo drive, pay particular attention to the edges and corners of housings and other components. Use suitable personal protective equipment.
- If you install the components of the system on a wall or on the floor, dust may be created by drilling. Use suitable personal protective equipment.
- Use only suitable installation and transport equipment.
- Prevent trapping and crushing by suitable protective measures.
- Use only suitable tools. If specified, use special tools.
- Use lifting equipment and tools in a proper manner.
- Do not step under suspended loads.
- Liquid spills on the floor must be removed immediately.

# 3 Product description

The servo drives of the smartServo BL 4000-C series are smart AC servo drives for controlling three-phase synchronous motors, torque motors and linear motors. The servo drives can be used in a universal manner, since they can be combined with a wide range of encoder systems and motors. Due to their extensive parameterisation options, they can be adapted to a variety of different applications. Servo drives of the BL 4000-C series are intended for use as devices installed in control cabinets. The connection to a superordinate control system can be realised by way of the integrated EtherCAT/PROFINET or CAN interface.

## 3.1 Type designation

Type key using the example of a BL 4104-C.

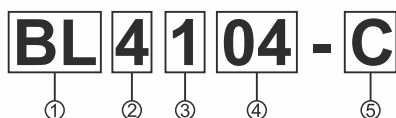

Figure 1: Nomenclature

Pos.	Description
1	Type designation: Basic Line
2	4th servo drive product family
3	Mains power connection: 1 = single-phase / 3 = three-phase
4	Nominal current in [A <sub>eff</sub> ]
5	C: Cabinet (control cabinet device) D: Decentral (separate from the motor) M: Mounted (mounted on the motor)

Based on this, the following type designations are used:

Designation	Description
BL 4000-C	All control cabinet servo drives of the Basic Line series, both single-phase as well as three-phase
BL 4100-C	All single-phase control cabinet servo drives of the Basic Line series
BL 4300-C	All three-phase control cabinet servo drives of the Basic Line series
BL 4104-C	A single-phase control cabinet servo drive with 4 A <sub>eff</sub> rated current



## 3.2 Device view

### > Front view

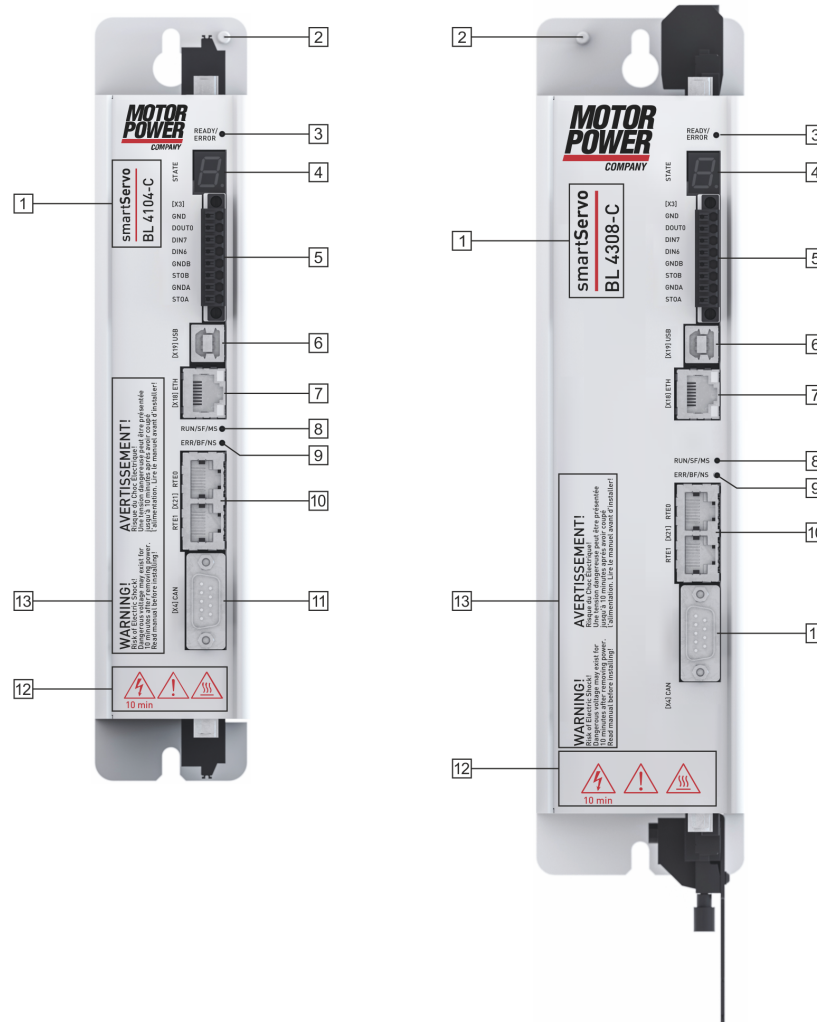

Figure 2: Front view of a BL 4104-C (left) and a BL 4308-C (right)

01	Product name	08	LED (RUN/SF/MS)
02	Earthing screw	09	LED (ERR/BF/MS)
03	Status indicator LED (READY, ERROR, ENABLE)	10	[X21] Real-time Ethernet interface
04	Seven-segment status indicator	11	[X4] CANOpen interface
05	[X3] STO interface (STOA, STOB), Limit switch (DIN6, DIN7), Dig. output (DOUT0)	12	Safety Symbols as per ISO 7000
06	[X19] USB interface	13	Warnings
07	[X18] Ethernet interface		

› Top view

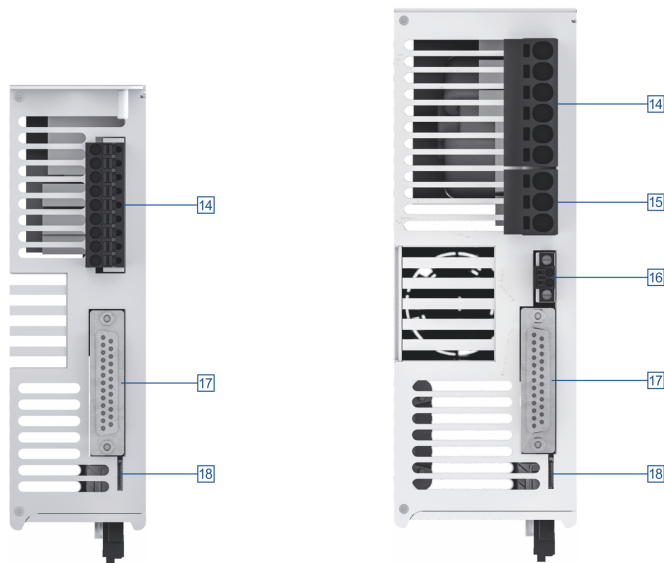

Figure 3: Top view of a BL 4100-C (left) and a BL 4300-C (right)

14	[X9] Power supply	17	[X1] I/O communication
15	[X9A] Braking resistor (BL 4300-C)	18	Slot for microSD cards
16	[X9B] 24 V supply (BL 4300-C)		

› Bottom view

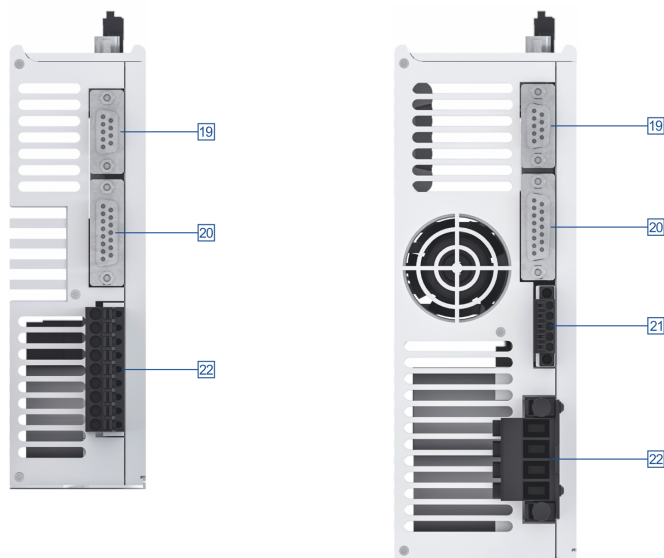

Figure 4: Bottom view of a BL 4100-C (left) and a BL 4300-C (right)

19	[X2A] Resolver/ analogue Hall sensors	21	[X6A] Motor brake / HIPERFACE DSL® (BL 4300-C)
20	[X2B] Multi-encoder	22	[X6] Motor connection

## 3.3 Features

All of the servo drives of this series have the following features:

### › Integrated fieldbus interfaces

- CANopen interface
- EtherCAT interface (CoE)
- PROFINET interface (standard telegrams, based on PROFIdrive)

### › Integrated universal shaft encoder evaluation for the following encoder types:

- Resolvers
- Analogue and digital incremental encoders with and without commutation signals
- High-resolution Stegmann incremental encoders with HIPERFACE®
- High-resolution Sick incremental encoders with HIPERFACE DSL® (single-cable variant)
- High-resolution Heidenhain incremental encoders with EnDat 2.2 (ENDAT22)
- Master frequency input/output and pulse direction interface

### › Suitable motors

- Permanent-magnet synchronous machines with sinusoidal EMF
- Torque motors
- Linear motors
  - Air-core and iron-core linear motors with a low motor inductance (0,5 ... 4 mH)
  - Automatic determination of the motor parameters

### › User-friendly parameterisation with the MPC ServoCommander software

- Adjustment of all of the parameters via a PC and online representation of operating parameters and diagnostic messages
- User-guided initial start-up, loading and saving of parameter sets as well as offline parameterisation are possible
- Oscilloscope function for optimising the drive and for analysing the PLC I/O coupling
- Supported languages: German, English
- Automatic motor identification and procedures for the automatic determination of the commutation position in the case of encoders without a commutation track
- Automatic adjustment of the control circuits for current, speed and position control

### › Integrated functional safety

- "Safe Torque Off (STO)" safety function integrated in the device
- SS1 functionality possible

### › Homing and positioning

- Integrated positioning control with a wide range of functions as per "CAN in Automation (CiA) DSP402" plus numerous additional application-specific functions.
- Jerk-free or time-optimal positioning, relative or absolute with regard to a reference point. Point-to-point positioning with and without smooth position transitions.
- High-speed sample inputs for triggering the storage of position marks
- Numerous homing methods
- Rotor and position triggers

### › Brake control and automatic brake

- Direct control of a motor holding brake with high current without using an external relay
- Adjustable brake delay times
- "Automatic brake" for deactivating the power section during longer breaks to save energy

### › Electrical characteristics

- Wide-range supply input (AC)
- "Soft switch-on" features for the soft precharging and quick charging of the DC bus
- DC bus coupling between devices with the same mains power supply for buffering the brake energy
- Improved monitoring and analysis of the mains power supply by a direct measurement of the mains voltage

### › Applications

- Speed- and angle-synchronous operation with an electronic gear unit via the incremental encoder input or fieldbus. Extensive modes of operation for synchronisation, e.g. "flying saw"
- Jog mode, teach-in mode, motion programs, torque-limited set control and much more

### › Special control features

- High control quality due to high-quality sensors, far superior to conventional market standards, and above-average processor resources
- Short cycle times, bandwidth in the current control circuit approx. 2 kHz (with  $t_i = 32 \mu\text{s}$ ), in the speed control circuit approx. 500 Hz (with  $t_n = 64 \mu\text{s}$ )
- Parameterisable band-stop filters for suppressing the natural frequency of the controlled system
- Load torque compensation for vertical axes
- Synchronisable internal clock system for the synchronisation with external clock sources for CANopen and EtherCAT fieldbus systems by way of an internal PLL

### › Certification and qualification

- Compliance with the current CE and EN standards without any additional external measures
- UL certification
- Completely closed, EMC-optimised housing for mounting on conventional switch cabinet mounting plates. The devices have an IP20 degree of protection.
- Integration of all of the required filters, e.g. line filters, filters for the 24 V supply and filters for the inputs and outputs, into the device in order to ensure compliance with the EMC regulations during operation (industrial environment)

# 4 Mounting

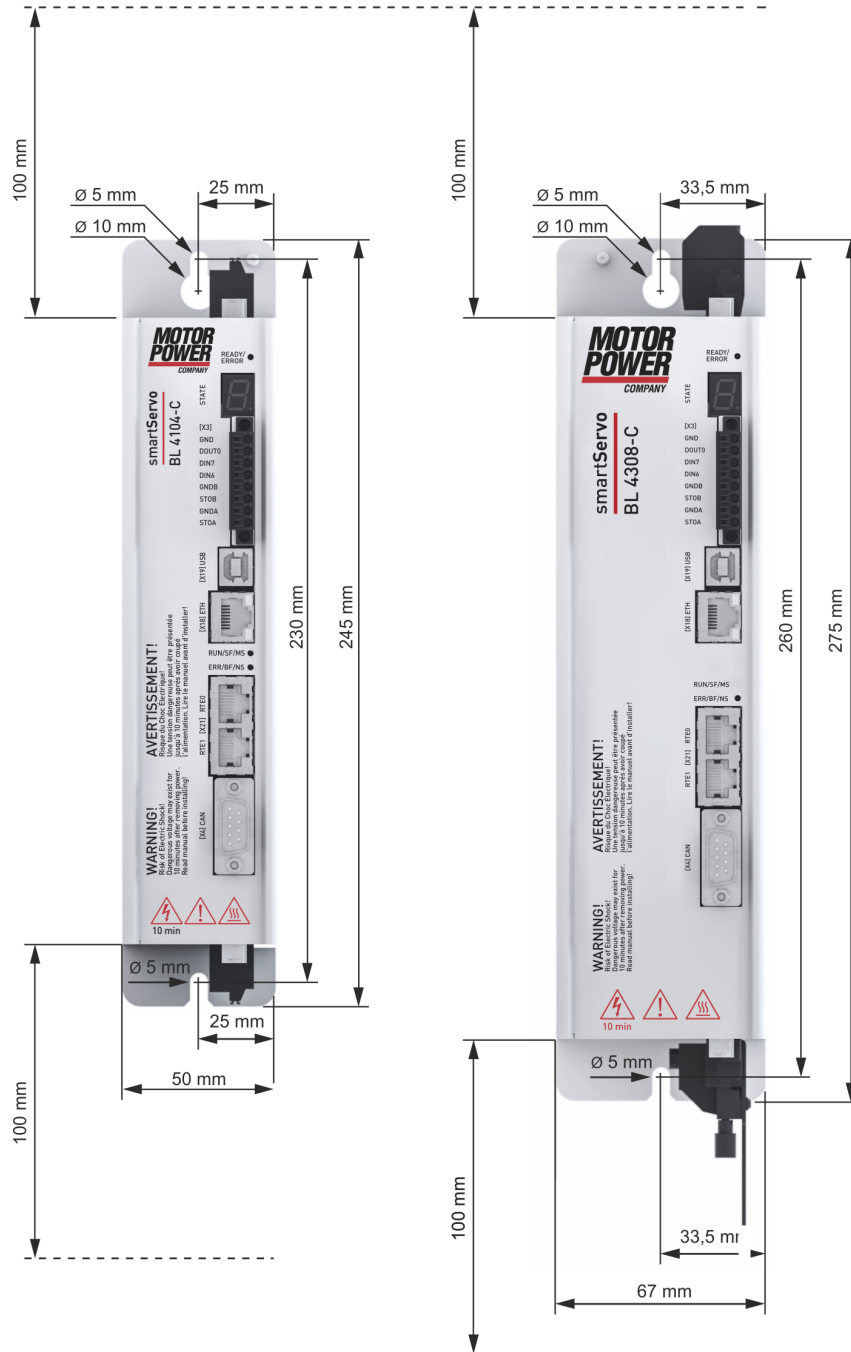

Figure 5: Servo drive BL 4100-C (left) and BL 4300-C (right)

The following requirements must be fulfilled for the installation of the servo drive:

- Follow the general set-up and safety rules and regulations concerning the installation.
- Follow the safety instructions in section 2.6 *Safety notes for installation and maintenance* on page 11.
- Use only suitable tools. If specified, use special tools.
- Always use suitable personal protective equipment, see section 2.5 *Personal protective equipment* on page 11.
- Servo drives of the BL 4000-C series are intended for use as devices installed in control cabinets.
- Installation position: Vertical with supply lines [X9] on top.
- The BL 4000-C servo drives have fastening tabs at the top and bottom. These tabs are used to mount the servo drive vertically to a control cabinet plate with two M5 screws. Recommended tightening torque for an M5 screw of property class 5.6: 2.8 Nm.
- Keep a minimum distance of 100 mm above and under the device with regard to other components in order to ensure sufficient ventilation. For optimal wiring of the motor cable and angle encoder cable under the device, an installation clearance of 150 mm is recommended.
- The BL 4000-C servo drives may be installed directly next to one another on a heat-dissipating back plate, provided that they are installed properly and used as intended. Excessive heating may cause premature ageing and/or damage.

## 5 Electrical installation

This chapter provides all of the relevant information for the electrical installation of a servo drive of the BL 4000-C series with an integrated "Safe Torque Off (STO)" safety function.

### 5.1 Notes concerning the safe and EMC-compliant installation

#### 5.1.1 Explanations and terminology

Electromagnetic compatibility (EMC) or electromagnetic interference (EMI) includes the following requirements:

- Sufficient **immunity** of an electrical installation or an electrical device against external electrical, magnetic or electromagnetic interferences via cables or the environment.
- Sufficiently small **unwanted emission** of electrical, magnetic or electromagnetic interference from an electrical installation or an electrical device to other devices in the vicinity via cables or the environment.

#### 5.1.2 General information about electromagnetic compatibility

The interference emission and interference immunity of a servo drive always depend on the overall drive concept consisting of the following components:

- Power supply
- Servo drive
- Motor
- Electromechanical system
- Configuration and type of wiring
- Superordinate control system

In order to increase interference immunity and to decrease interference emissions, the servo drive has numerous integrated filters so that it can be used without additional shielding and filtering devices in most applications.



### 5.1.3 Proper wiring

The following must be observed for servo drives of type BL 4000-C to ensure a safe and EMC-compliant design of the drive system:

**⚠ DANGER ⚠ Dangerous electrical voltage!**

For safety reasons, all of the PE earth (ground) conductors must be connected prior to the initial operation of the system. The shields must be connected on both sides.

The EN 61800-5-1 regulations concerning protective earthing (grounding) must be complied with during the installation.

- In order to keep the leakage currents and losses in the motor connecting cable as small as possible, the servo drive should be located as close to the motor as possible (see also section 5.1.4 *Operation with long motor cables* on page 26).
- The motor cable and angle encoder cable must be shielded.
- Connect the shield of the motor cable to the back panel of the control cabinet by way of suitable shield terminals. The unshielded cable end should not be longer than 80 mm.
- The mains-end PE connector must be connected to the PE connection point of the supply connector [X9].
- The earthing (grounding) screw of the mounting plate must also be connected to the mains-side PE connector via a separate earth lead:  
See section 3.2 *Device view* on page 17.
- The cross-section of each earth lead must not be smaller than the cross-section of the supply leads (L/N or L1-L3).
- The inner PE conductor of the motor cable must be connected to the PE connection point of the motor connector [X6].
- The signal lines must be as far away from the power cables as possible. They should not be laid in parallel. If intersections cannot be avoided, they should be installed at right angles if possible.
- Unshielded signal and control lines should not be used. If their use is inevitable, they should at least be twisted.
- Even shielded cables will inevitably have short unshielded ends (unless shielded connector housings are used).

In general, the following applies:

- Connect the inner shields to the associated pins of the connectors.
- Connect the overall shield on the motor side to the connector or motor housing over a large contact area.

## 5.1.4 Operation with long motor cables

### **INFORMATION** Compliance with the EMC standard EN 61800-3

Compliance with the EMC standard EN 61800-3 is ensured only for a motor cable length of 25 m maximum. Operation with longer cables is not permissible.

In applications where long motor cables are required or when using motor cables with unacceptably high cable capacitance, the filters, the power amplifier and the sensors may be overloaded.

To avoid such problems, we strongly recommend the use of cables with <math><150\text{ pF/m}</math> cable capacitance in applications where long motor cables are required (please contact your motor cable supplier if necessary).

## 5.1.5 ESD protection

### **NOTICE** Damage to property due to ESD (electrostatic discharge)

At unassigned plug connectors, damage can occur to the device or to other system parts as a result of ESD (electrostatic discharge). To prevent this type of damage, comply with the following:

- Ensure proper earthing of all of the system components and wire the servo drive completely prior to switching on the voltage supply.
- The person commissioning the system as well as the service and maintenance personnel must have undergone ESD training and wear corresponding footwear.
- When handling the system, e.g. the USB connector, it is useful to touch the control cabinet housing (should be at PE potential) with your hand prior to touching one of the connectors of the servo drive.

## 5.2 Additional requirements for the UL approval

### › Mains power supply protection

Integral solid state short circuit protection does not provide branch circuit protection. Branch circuit protection must be provided in accordance with the Manufacturer Instructions, National Electrical Code and any additional local codes.

- BL 4100-C:  
Suitable For Use On A Circuit Capable Of Delivering Not More Than 5,000 rms Symmetrical Amperes, 240 Volts Maximum When Protected by A Circuit Breaker Having An Interrupt Rating Not Less Than 10 rms Symmetrical Amperes, 240 Volts Maximum.  
Observe the following specification for the main fuse: Listed Circuit Breaker according to UL 489, rated 277 Vac, 10 A, SCCR 10 kA
- BL 4300-C:  
Suitable For Use On A Circuit Capable Of Delivering Not More Than 5,000 rms Symmetrical Amperes, 480 Volts Maximum When Protected by A Circuit Breaker Having An Interrupt Rating Not Less Than ( $I_n$ ) rms Symmetrical Amperes, 480 Volts Maximum.  
Observe the following specification for the main fuse: Listed Circuit Breaker according to UL 489, rated 480Y/277 Vac, ( $I_n$ ) A, SCCR 10 kA

BL 4304-C: ( $I_n$ ) = 10

BL 4308-C: ( $I_n$ ) = 10

BL 4312-C: ( $I_n$ ) = 16

### › Wiring requirements and environmental conditions

- Use 60 / 75 °C copper conductors.
- For use in Pollution Degree 2 Environment only.

### › Motor overload protection

For effective motor protection, the motor parameters and the I<sup>2</sup>t-Integral must be parameterised appropriately (see section *Configuration of the motor data* in the Product manual smartServo BL 4000-C).

## 5.3 Connector BL 4100-C: power supply [X9]

Servo drives of the BL 4100-C series must be connected to the voltage supply and an optional brake resistor in accordance with the following illustration.

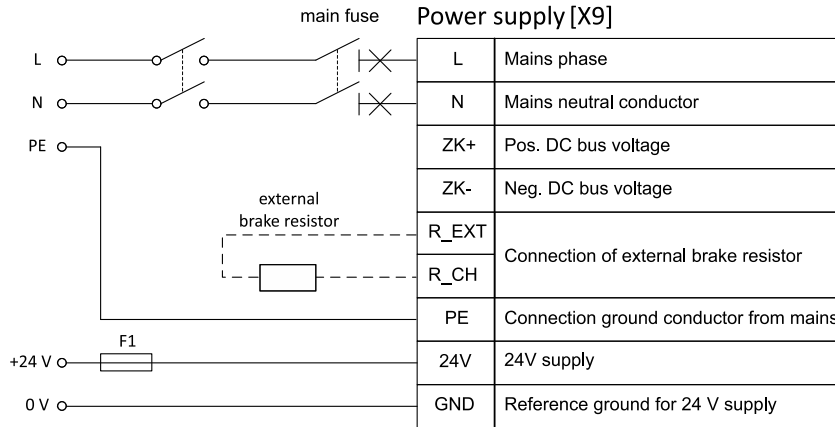

Figure 6: Connection of a BL 4100-C to the power supply [X9]

### **NOTICE** Risk of damage to the servo drive

The servo drive will be damaged in the following cases:

- reverse connection of the 24 V operating voltage connections,
- excessive operating voltage, or
- accidental interchanging of the operating voltage and motor connectors.

### **NOTICE** Risk of destruction due to a connection with reverse polarity

If the polarity of the 24 V supply at [X9] or [X9B] is reversed, the servo drive and the PC will be destroyed. It is essential that you follow the correct connection instructions.

A 24 V supply and a single-phase mains power supply are required to operate a BL 4100-C. A single-phase automatic circuit breaker must be installed in the mains power supply line (see section *Cable type and configuration [X9]* on page 29). In addition, you can protect the servo drive with an AC/DC-sensitive residual-current device (RCD) with 300 mA minimum. Direct DC coupling of the DC buses of several devices with equal DC bus voltage is possible by way of the terminals ZK+ and ZK- (see section *DC bus coupling* in the Product manual BL 4000-C). The servo drive has an internal brake chopper and an internal braking resistor. For higher braking power, an external braking resistor can be connected to connector [X9] in parallel to the internal braking resistor.

The servo drive must be connected to earth (ground) with its PE connectors (section 5.1.3 *Proper wiring* on page 25).

First, wire the servo drive completely. Then, switch on the 24 V supply and the mains power supply.

### > Configuration on the device [X9]

Weidmüller SL 5.08HC/09/90G 3.2SN BK BX

### > Mating connector [X9]

Weidmüller BLF 5.08HC/09/180 SN BK BX

### > Pin assignment [X9]

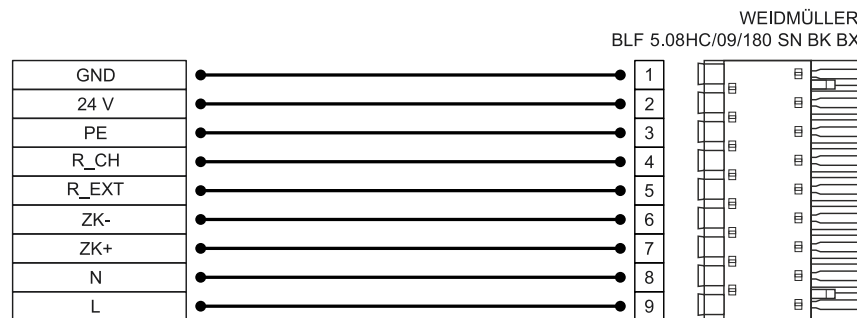

Figure 7: Pin assignment: „power supply connector [X9]“

Pin	Name	Specification
1	GND	Supply voltage reference potential
2	24V	Supply voltage for the control module and holding brake
3	PE	Connection of the protective earth (ground) conductor of the mains power supply
4	R_CH	Braking resistor connection
5	R_EXT	Braking resistor connection
6	ZK-	Neg. DC bus voltage
7	ZK+	Pos. DC bus voltage
8	N	Neutral conductor
9	L	Phase conductor/mains phase

### > Cable type and configuration [X9]

The cable names that are stated refer to cables made by Lapp. They have proved to be reliable and are successfully used in many applications. However, it is also possible to use comparable cables from other manufacturers, for example Lütze or Helukabel.

A single-phase circuit breaker with the listed characteristics ("Circuit breaker") must be used in the mains supply line.

LAPP KABEL ÖLFLEX CLASSIC 110

Device type	Cable type	Specification (L, N, PE)	Circuit breaker
BL 4102-C	3 G 1.0	3 x 1,0 mm <sup>2</sup> (AWG 18)	B 10
BL 4104-C	3 G 1.0	3 x 1,0 mm <sup>2</sup> (AWG 18)	B 10

## 5.4 Connector BL 4300-C: power supply [X9], [X9A], [X9B]

Servo drives of the BL 4300-C series must be connected to the voltage supply and an optional brake resistor in accordance with the following illustration.

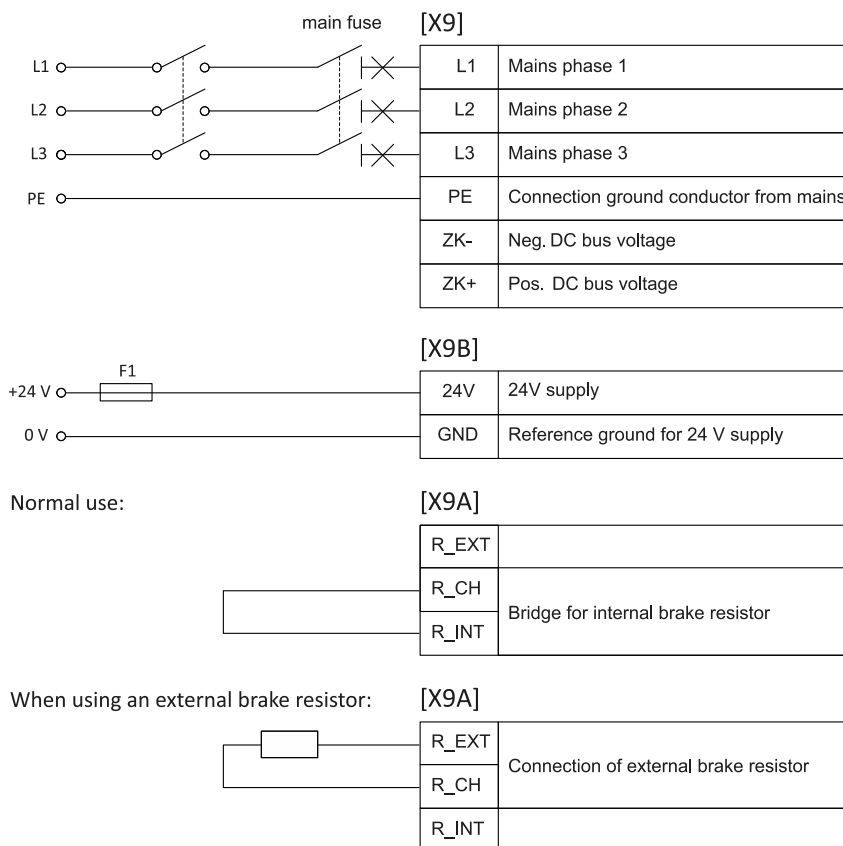

Figure 8: Connection of a BL 4300-C to the power supply [X9]

**NOTICE Risk of damage to the servo drive**

The servo drive will be damaged in the following cases:

- reverse connection of the 24 V operating voltage connections,
- excessive operating voltage, or
- accidental interchanging of the operating voltage and motor connectors.

**NOTICE Risk of destruction due to a connection with reverse polarity**

If the polarity of the 24 V supply at [X9] or [X9B] is reversed, the servo drive and the PC will be destroyed. It is essential that you follow the correct connection instructions.

A 24 V supply and a three-phase mains power supply are required to operate a BL 4300-C. A three-phase automatic circuit breaker must be installed in the mains power supply line (see *Cable type and configuration [X9], [X9A], [X9B]* on page 32). In addition, you can protect the servo drive with an AC/DC-sensitive residual-current device (RCD) with 300 mA minimum. Direct DC coupling of the DC buses of several devices with equal DC bus voltage is possible by way of the terminals ZK+ and ZK- (see section *Zwischenkreiskopplung* in the Product Manual BL 4000-C). The servo drive has an

internal brake chopper and an internal braking resistor. If this is used, a bridge must be wired to [X9A]. For more braking power, an external braking resistor can be connected to the connector [X9A] instead of the bridge.

The servo drive must be connected to earth (ground) with its PE connectors (Please also refer to section 5.1.3 *Proper wiring* on page 25).

First, wire the servo drive completely. Then, switch on the 24 V supply and the mains power supply.

### › Configuration on the device [X9], [X9A], [X9B]

X9: Weidmüller SV 7.62HP/06/90G 3.5SN BK BX

X9A: Weidmüller SV 7.62HP/03/90G 3.5SN BK BX

X9B: Weidmüller SC 3.81/02/90F 3.2SN BK BX

### › Mating connector [X9], [X9A], [X9B]

X9: Weidmüller BVF 7.62HP/06/180 SN BK BX

X9A: Weidmüller BVF 7.62HP/03/180 SN BK BX

X9B: Weidmüller BCF 3.81/02/180F SN BK BX

### › Pin assignment [X9], [X9A], [X9B]

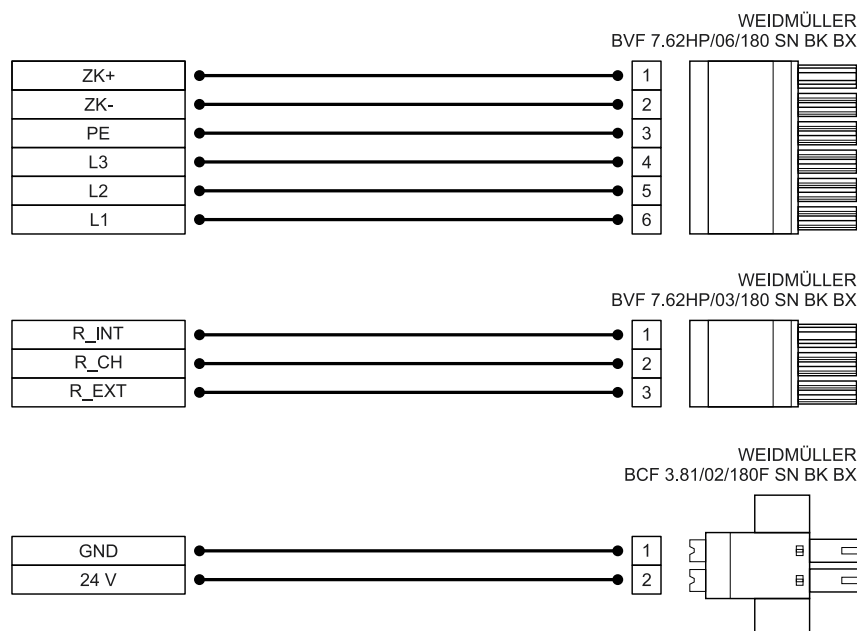

Figure 9: Pin assignment: „power supply connector [X9], [X9A], [X9B]“

Pin X9	Name	Specification
1	ZK+	Pos. DC bus voltage
2	ZK-	Neg. DC bus voltage
3	PE	Connection of the protective earth (ground) conductor of the mains power supply
4	L3	Phase conductor/mains phase 3
5	L2	Phase conductor/mains phase 2
6	L1	Phase conductor/mains phase 1

Pin X9A	Name	Specification
1	R_INT	Internal braking resistor connection
2	R_CH	Braking resistor connection
3	R_EXT	External braking resistor connection

Pin X9B	Name	Specification
1	GND	Supply voltage reference potential
2	24V	Supply voltage for the control module and holding brake

### › Cable type and configuration [X9], [X9A], [X9B]

The cable names that are stated refer to cables made by Lapp. They have proved to be reliable and are successfully used in many applications. However, it is also possible to use comparable cables from other manufacturers, for example Lütze or Helukabel.

A three-phase circuit breaker with the listed characteristics ("Circuit breaker") must be used in the mains supply line.

LAPP KABEL ÖLFLEX CLASSIC 110

Device type	Cable type	Specification (L1, L2, L3, PE)	Circuit breaker
BL 4304-C	4 G 1.0	4 x 1,0 mm <sup>2</sup> (AWG 18)	B 10
BL 4308-C	4 G 1.5	4 x 1,5 mm <sup>2</sup> (AWG 16)	B 10
BL 4312-C	4 G 2.5	4 x 2,5 mm <sup>2</sup> (AWG 14)	B 16



## 5.5 Connector BL 4100-C: motor [X6]

The motor is connected to the terminals U,V,W. An analog motor temperature sensor can be connected to the terminals MT+ and MT- if it is routed together with the motor phases in one cable. Alternatively, it can be connected via the encoder cable to [X2A] or [X2B] (see section *Motor temperature monitoring system* in the product manual BL 4000-C). A holding brake of the motor can be connected to terminals BR+ and BR-. If a motor with a HIPERFACE DSL® encoder is used, this encoder is also connected via [X6].

### › Configuration on the device [X6]

Weidmüller SL 5.08HC/09/90G 3.2SN BK BX

### › Mating connector [X6]

Weidmüller BLF 5.08HC/09/180 SN BK BX

### › Pin assignment: motor with a motor temperature sensor

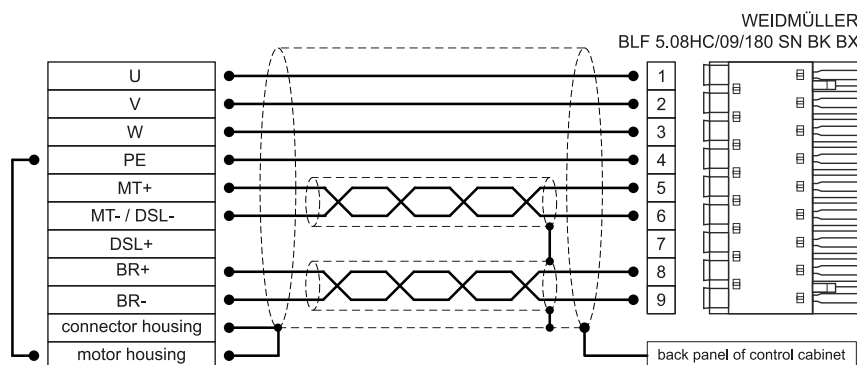

Figure 10: Pin assignment: motor connector (motor temperature sensor) [X6]

Pin	Namen	Specification
1	U	Motor phase U
2	V	Motor phase V
3	W	Motor phase W
4	PE	Protective earth conductor of the motor
5	MT+	Motor temperature sensor +
6	MT-/DSL-	Motor temperature sensor -
7	DSL+	
8	BR+	Holding brake +
9	BR-	Holding brake -

### › Pin assignment: motor with HIPERFACE DSL®

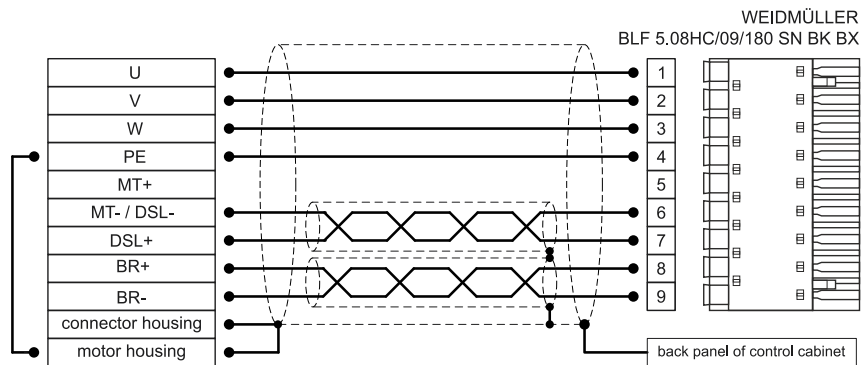

Figure 11: Pin assignment: motor connector (HIPERFACE DSL®) [X6]

Pin	Name	Specification
1	U	Motor phase U
2	V	Motor phase V
3	W	Motor phase W
4	PE	Protective earth conductor of the motor
5	MT+	
6	MT- / DSL-	HIPERFACE DSL -
7	DSL+	HIPERFACE DSL +
8	BR+	Holding brake +
9	BR-	Holding brake -

### › Cable type and configuration [X6]

The cable names that are stated refer to cables made by Lapp. However, it is also possible to use comparable cables from other manufacturers, for example Lütze or Helukabel.

For fixed installation: LAPP KABEL ÖLFLEX SERVO 719 CY

For highly flexible use (drag chains): LAPP KABEL ÖLFLEX SERVO FD 796 CP

Device type	Cable type	Specification (U, V, W, PE)
BL 4102-C	4 G 1,0 + 2 x (2 x 0,75)	4 x 1,0 mm <sup>2</sup> (AWG 18)
BL 4104-C	4 G 1,0 + 2 x (2 x 0,75)	4 x 1,0 mm <sup>2</sup> (AWG 18)

#### **INFORMATION** Comply with the required minimum cross-section

Always observe the minimum cross-sections for the lines U, V, W and PE according to the above table. Comply also with the maximum permissible cable capacity as per section 6.4 *BL 4100-C: Motor connector [X6]* on page 58.

**> Connection notes [X6]**

Connect the inner and outer cable shield with the greatest possible surface area to the back panel of the control cabinet by way of suitable EMC terminals (e.g. icotek LFZ/SKL, SFZ/SKL or PFSZ-MSKL). The unshielded cable end should not be longer than 80 mm. An existing holding brake in the motor must be connected to the terminals BR+ and BR-. Please note the maximum output current that is provided by the servo drive.

**⚠ DANGER ⚠ Dangerous electrical voltage!**

The signals for the temperature sensor "MT-" and "MT+" at the motor connector [X6] must be connected to protective extra-low voltage (PELV) on the motor side and they must be insulated against the motor phases.

**⚠ WARNING Risk of injury**

The brake output of the servo drive (BR+, BR-) must not be used as the sole stop element in safety-oriented applications.

**NOTICE Risk of destruction due to the mix-up of connectors**

The servo drive may be irreparably damaged if the connectors for the motor [X6] and supply [X9] are mixed up.

## 5.6 Connector BL 4300-C: motor [X6], [X6A]

The motor is connected to the terminals U,V,W. An analog motor temperature sensor can be connected to the terminals MT+ and MT- if it is routed together with the motor phases in one cable. Alternatively, it can be connected via the encoder cable to [X2A] or [X2B] (see section *Motor temperature monitoring system* in the product manual BL 4000-C). A holding brake of the motor can be connected to terminals BR+ and BR-. If a motor with a HIPERFACE DSL<sup>®</sup> encoder is used, this encoder is connected via [X6A].

### › Configuration on the device [X6], [X6A]

X6: Weidmüller BVL 7.62HP/04/90 3.5SN BK BX + mounting blocks(shield connection)

X6A: Weidmüller SC 3.81/05/90F 3.2SN BK BX

### › Mating connector [X6], [X6A]

X6: Weidmüller SVZ 7.62HP/04/180RSH180I SN BK BX (Tightening torque: 0.6 Nm)

X6A: Weidmüller BCF 3.81/05/180F SN BK BX

### › Pin assignment [X6], [X6A]: motor with a motor temperature sensor

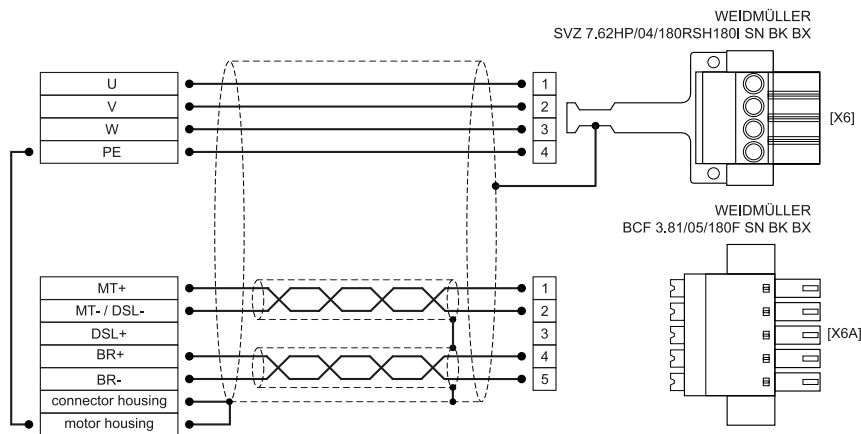

Figure 12: Pin assignment: motor connector (motor temperature sensor) [X6]

Pin X6	Name	Specification
1	U	Motor phase U
2	V	Motor phase V
3	W	Motor phase W
4	PE	Protective earth conductor of the motor

Pin X6A	Name	Specification
1	MT+	Motor temperature sensor +
2	MT-/ DSL-	Motor temperature sensor -
3	DSL+	
4	BR+	Holding brake +
5	BR-	Holding brake -

### > Pin assignment [X6], [X6A]: motor with HIPERFACE DSL<sup>®</sup>

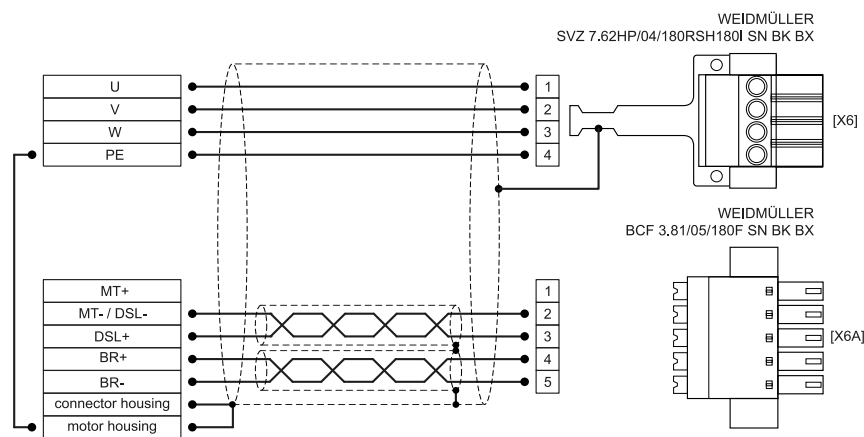

Figure 13: Pin assignment: motor connector (HIPERFACE DSL<sup>®</sup>) [X6]

Pin X6	Name	Specification
1	U	Motor phase U
2	V	Motor phase V
3	W	Motor phase W
4	PE	Protective earth conductor of the motor

Pin X6A	Name	Specification
1	MT+	
2	MT-/ DSL-	HIPERFACE DSL-
3	DSL+	HIPERFACE DSL+
4	BR+	Holding brake +
5	BR-	Holding brake -

### > Cable type and configuration [X6], [X6A]

The cable names that are stated refer to cables made by Lapp. However, it is also possible to use comparable cables from other manufacturers, for example Lütze or Helukabel.

For fixed installation: LAPP KABEL ÖLFLEX SERVO 719 CY

For highly flexible use (drag chains): LAPP KABEL ÖLFLEX SERVO FD 796 CP

Device type	Cable type	Specification (U, V, W, PE)
BL 4304-C	4 G 1,0 + 2 x (2 x 0,75)	4 x 1,0 mm <sup>2</sup> (AWG 18)
BL 4308-C	4 G 1,5 + 2 x (2 x 0,75)	4 x 1,5 mm <sup>2</sup> (AWG 16)
BL 4312-C	4 G 2,5 + 2 x (2 x 1,0)	4 x 2,5 mm <sup>2</sup> (AWG 14)

**INFORMATION** Comply with the required minimum cross-section

Always observe the minimum cross-sections for the lines U, V, W and PE according to the above table. Comply also with the maximum permissible cable capacity as per section 6.5 *BL 4300-C: Motor connector [X6], [X6A]* on page 61.

**> Connection notes [X6], [X6A]**

Connect the inner and outer cable shield with the greatest possible surface area to the shield connection of [X6] and fix the cable for example with cable ties. The fixing screws must be firmly tightened to ensure a good PE connection. The unshielded cable end should not be longer than 50 mm.

An existing holding brake in the motor must be connected to the terminals BR+ and BR-. Please note the maximum output current that is provided by the servo drive.

**⚠ DANGER** ⚠ **Dangerous electrical voltage!**

The signals for the temperature sensor "MT-" and "MT+" at the motor connector [X6] must be connected to protective extra-low voltage (PELV) on the motor side and they must be insulated against the motor phases.

**⚠ WARNING** **Risk of injury**

The brake output of the servo drive (BR+, BR-) must not be used as the sole stop element in safety-oriented applications.

**NOTICE** **Risk of destruction due to the mix-up of connectors**

The servo drive may be irreparably damaged if the connectors for the motor [X6] and supply [X9] are mixed up.

## 5.7 Connector: resolvers/analogue Hall encoders [X2A]

Two different encoder types can be connected to the 9-pin D-Sub connector:

- Resolvers
- Analogue Hall generators with tracks that are offset by 90° (sine/cosine)

Diverging from the analogue evaluation via the X2B interface, this input has a higher resolution and it is possible to read in higher amplitudes.

### > Configuration on the device [X2A]

D-SUB connector, 9-pin type, female

### > Mating connector [X2A]

- D-SUB connector, 9-pin type, male
- Housing for a 9-pin D-SUB connector with locking screws of type 4/40 UNC

### > Pin assignment [X2A]

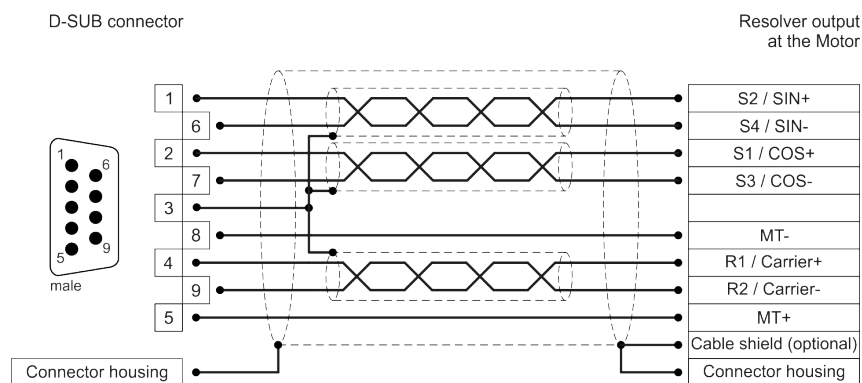

Figure 14: Pin assignment: resolver connector [X2A]

- The outer shield is always connected to PE (connector housing) on the servo drive side.
- The three inner shields are connected to PIN 3 of X2A on one side of the servo drive.

Pin	Name	Specification
1	S2	SINE track signal, differential
6	S4	Analogue Hall sensor (SINE)
2	S1	COSINE track signal, differential
7	S3	Analogue Hall sensor (COSINE)
3	GND	Shield for signal pairs (inner shield)
8	MT-	Temperature sensor reference potential
4	R1	Carrier signal for the resolver
9	R2	
5	MT+	Motor temperature sensor, normally closed contact, PTC, NTC, KTY

**INFORMATION** Only one motor temperature sensor can be connected

The motor temperature sensor can either be connected to X2A, X2B or X6. It is not possible to connect several sensors at a time.

**INFORMATION** Avoiding EMC interferences

The outer cable shield must be connected to the housing of the angle encoder connector with the greatest possible surface area (with low impedance).

### > Cable type and configuration [X2A]

The cable names that are stated refer to cables made by Lapp. However, it is also possible to use comparable cables from other manufacturers, for example Lütze or Helukabel.

LAPP KABEL ÖLFLEX SERVO 728 CY; 3 x (2 x 0.14) + 2 x (0.5);

with an overall tinned CU shield, angle measurement error up to approx. 0.7° with a cable length of 25 m, to be used 2 x (0.5) for the resolver carrier.

**For highly flexible applications:**

LAPP KABEL ÖLFLEX SERVO FD 798 CP; 3 x (2 x 0.14) + 2 x (0.5);

with an overall tinned CU shield, angle measurement error up to approx. 0.7° with a cable length of 25 m, to be used 2 x (0.5) for the resolver carrier.



## 5.8 Connector: encoder [X2B]

Different types of encoders can be connected to the 15-pin D-Sub connector (see 6.7):

- Analogue incremental encoders (1 V<sub>ss</sub>)
- Incremental encoders with a serial interface (RS485 level, e.g. EnDat, HIPERFACE<sup>®</sup>, BISS)
- Digital incremental encoders (RS422, HALL sensors)

It is also possible to evaluate an optional error signal (AS/NAS) via pin 6. With some incremental encoders, it is possible to detect and signal soiling or other faults/malfunctions of the measuring system via an output (AS or NAS). The error signal can be evaluated by digital as well as analogue incremental encoders.

In the case of analogue incremental encoders, the evaluation is only possible if no commutation track (Z1) is parameterised and connected. The evaluation of the error signal can be inverted.

### › Configuration on the device [X2B]

D-SUB connector, 15-pin type, female

### › Mating connector [X2B]

- D-SUB connector, 15-pin type, male
- Housing for a 15-pin D-SUB connector with locking screws of type 4/40 UNC

#### **NOTICE** Damage to property caused by an incorrect power supply

If an incorrect power supply is used, the encoder may be destroyed. Ensure that the correct voltage is activated prior to connecting the encoder to [X2B]. To do so, start the MPC ServoCommander parameterisation software and select the **Parameters/Device parameters/Angle encoder settings**.

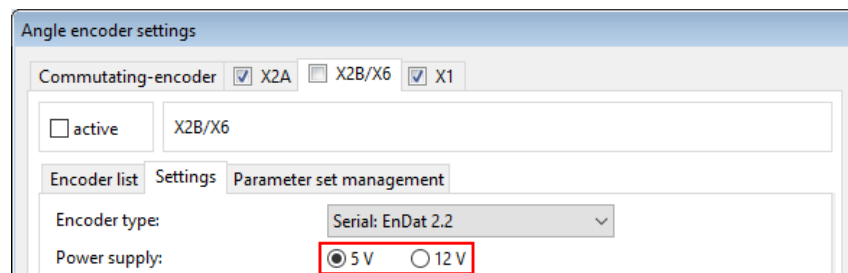

Figure 15: Angle encoder settings: Parameterisation of supply voltage

## > Pin assignment: analogue incremental encoders

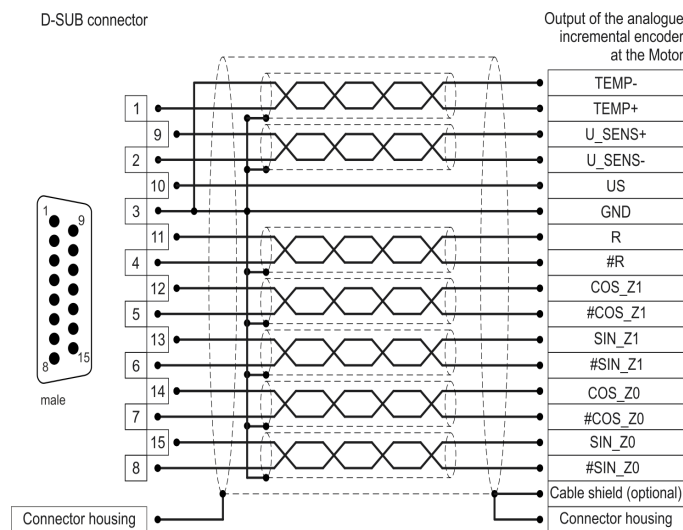

Figure 16: Pin assignment: analogue incremental encoders [X2B]

Pin	Name	Specification
1	MT+	Motor temperature sensor, normally closed contact, PTC, NTC, KTY
9	U_SENS+	Sensor cables for the encoder supply. In case of long cables, connect to US/GND at the motor end.
2	U_SENS-	
10	US	Operating voltage for incremental encoders
3	GND	Associated reference potential
11	R	Index pulse track signal (differential) of the high-resolution incremental encoder
4	#R	
12	COS_Z1 / D+	COSINE commutation signal (differential) of the high-resolution incremental encoder
5	#COS_Z1 / D-	
13	SIN_Z1 / C+	SINE commutation signal (differential) of the high-resolution incremental encoder
6	#SIN_Z1 / C-	
14	COS_Z0 / B+	COSINE track signal (differential) of the high-resolution incremental encoder
7	#COS_Z0 / B-	
15	SIN_Z0 / A+	SINE track signal (differential) of the high-resolution incremental encoder
8	#SIN_Z0 / A-	

### INFORMATION Avoiding EMC interferences

The outer cable shield must be connected to the housing of the angle encoder connector with the greatest possible surface area (with low impedance).

> Pin assignment: incremental encoder with a serial interface

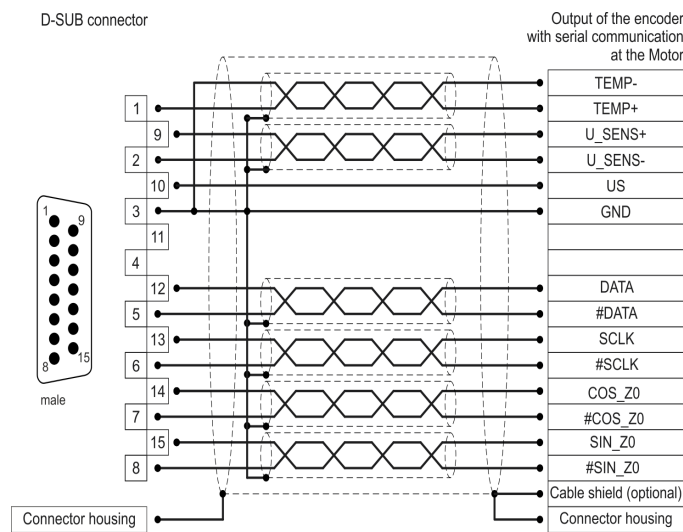

Figure 17: Pin assignment: incremental encoder with a serial interface [X2B]

Pin	Name	Specification
1	MT+	Motor temperature sensor, normally closed contact, PTC, NTC, KTY
9	U_SENS+	Sensor cables for the encoder supply. In case of long cables, connect to US/GND at the motor end.
2	U_SENS-	
10	US	Operating voltage
3	GND	Associated reference potential
11		
4		
12	DATA / SL+	Bidirectional RS485 data line (differential) (EnDat/HIPERFACE®, BiSS)
5	#DATA / SL-	
13	SCLK / MA+	Clock pulse output RS485 (differential) (EnDat, BiSS)
6	#SCLK / MA-	
14	COS_Z0 / B+	COSINE track signal (differential) of the high-resolution incremental encoder
7	#COS_Z0 / B-	
15	SIN_Z0 / A+	SINE track signal (differential) of the high-resolution incremental encoder
8	#SIN_Z0 / A-	

**INFORMATION** Avoiding EMC interferences

The outer cable shield must be connected to the housing of the angle encoder connector with the greatest possible surface area (with low impedance).

## ➤ Pin assignment: digital incremental encoder (RS422)

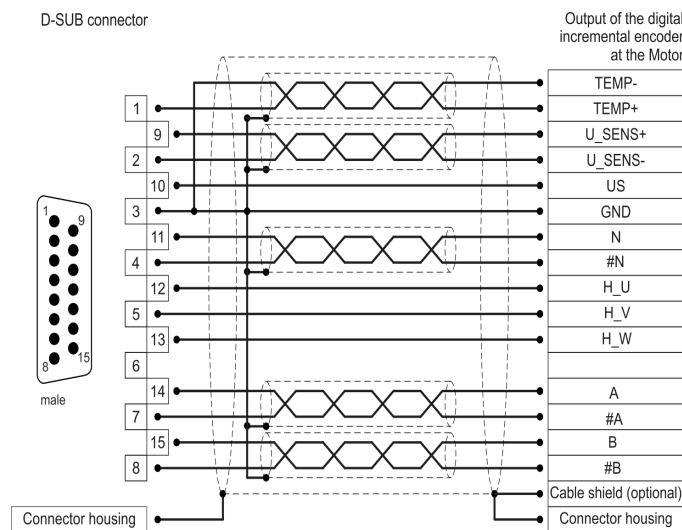

Figure 18: Pin assignment: digital incremental encoder (RS422) [X2B]

Pin	Name	Specification
1	MT+	Motor temperature sensor, normally closed contact, PTC, NTC, KTY
9	U_SENS+	Sensor cables for the encoder supply. In case of a long cable, connect to US/GND at the motor end.
2	U_SENS-	
10	US	Operating voltage for incremental encoders
3	GND	Associated reference potential
11	N / U <sub>a0</sub>	Index pulse RS422 (differential) of the digital incremental encoder
4	#N / $\bar{U}_{a0}$	
12	H_U	Phase U of the Hall sensor for commutation
5	H_V	Phase V of the Hall sensor for commutation
13	H_W	Phase W of the Hall sensor for commutation
6		
14	A / U <sub>a1</sub>	A track signal RS422 (differential) of the digital incremental encoder
7	#A / $\bar{U}_{a1}$	
15	B / U <sub>a2</sub>	B track signal RS422 (differential) of the digital incremental encoder
8	#B / $\bar{U}_{a2}$	

### **INFORMATION** Avoiding EMC interferences

The outer cable shield must be connected to the housing of the angle encoder connector with the greatest possible surface area (with low impedance).

## ➤ Cable type and configuration [X2B]

We recommend a minimum cross-section of 0.25 mm<sup>2</sup> for the angle encoder supply US and GND.

## 5.9 Connector: USB [X19]

The BL 4000-C servo drive has a Type B USB connector.

The correct operation requires a short USB cable (< 3 m) and the correct installation and earthing of the servo drive. If excessive malfunctions/faults lead to communication problems (frozen communication), the USB connector can be briefly disconnected to restart the communication. In any case, we recommend using certified and double-shielded cables with shielded plugs of the following type :

Type AB (USB 2.0 connecting cable, type A connector to type B connector) AWG28-1P

### **INFORMATION** Non-EMC-compliant wiring of the servo drive and motor

In case of non-EMC-compliant wiring of the servo drive and motor, compensating electric current may flow via the connected computer and the USB interface. This may lead to communication problems. To avoid this, we recommend using an electrically isolated USB adapter "Delock USB Isolator" (type 62588 by Delock) or a comparable adapter.

### **INFORMATION** Use USB only during commissioning

The USB interface should only be used during commissioning and not as a process interface in an application. In an industrial environment, the electrically much more robust Ethernet interface should be preferred instead.

### › Configuration on the device [X19]

USB connector (female), type B

### › Mating connector [X19]

USB connector (male), type B

### › Pin assignment USB [X19]

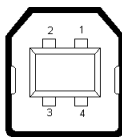

Figure 19: Pin assignment of the USB connector

Pin	Name	Specification
1		
2	D-	Data -
3	D+	Data +
4	GND	GND

## 5.10 Connector: standard Ethernet [X18]

The BL 4000-C servo drive has a network connector of the RJ45 type.

### > Configuration on the device [X18]

Female RJ45 connector, cat. 6

### > Mating connector [X18]

Male RJ45 connector

### > Pin assignment of the network connector [X18]

Cat.6 patch cable RJ45 LAN cable S-FTP/PIMF.

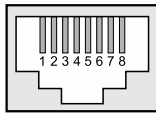

Figure 20: Pin assignment of the network connector

Pin	Name	Description	Colour
1	TX+	Transmission signal +	Yellow
2	TX-	Transmission signal -	Orange
3	RX+	Reception signal +	White
4	-	-	
5	-	-	
6	RX-	Reception signal -	Blue
7	-	-	
8	-	-	

## 5.11 Connector: real-time Ethernet [X21]

The connection to an EtherCAT or PROFINET network must be realised via two female RJ45 connectors. Details can be found in the Fieldbus manuals.

### > Configuration on the device [X21]

Female RJ45 connector, cat. 6

### > Mating connector [X21]

Male RJ45 connector

### > Pin assignment of the real-time Ethernet connector [X21]

Cat.6 patch cable RJ45 LAN cable S-FTP/PIMF.

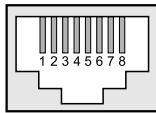

Figure 21: Pin assignment of the real-time Ethernet connector

Pin	Name	Description	Colour
1	TX+	Transmission signal +	Yellow
2	TX-	Transmission signal -	Orange
3	RX+	Reception signal +	White
4	-	-	
5	-	-	
6	RX-	Reception signal -	Blue
7	-	-	
8	-	-	

## 5.12 Connector: CAN bus [X4]

For trouble-free operation of the CAN bus communication, the following instructions must be observed

- Ideally, the individual nodes of the networks are always connected in a linear manner so that the CAN cable is looped through from servo drive to servo drive.
- A terminating resistor of 120  $\Omega$ , 5%, must be present on both ends of the CAN bus cable
- We advise against the use of intermediate plugs for cabling the CAN bus. However, if this is necessary, use metal connector housings for connecting the cable shield.

In order to keep interferences as low as possible ensure that

- the motor cables are not installed parallel to signal lines
- the motor cables comply with the specification
- the motor cables are properly shielded and earthed (grounded)

The cable used should be constructed as follows

- Shielded cables with exactly two twisted pairs must be used for cabling
- Use one twisted pair to connect CAN-H and CAN-L.
- The cores of the other pair are used jointly for CAN-GND.
- The shield of the cable is led to the CAN shield connections for all nodes

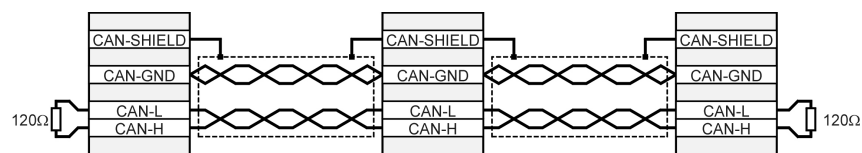

Figure 22: CAN bus cabling example



### › Configuration on the device [X4]

D-SUB connector, 9-pin type, male

### › Mating connector [X4]

- D-SUB connector, 9-pin type, female
- Housing for a 9-pin D-SUB connector with locking screws of type 4/40 UNC

### › Pin assignment [X4]

Pin	Name	Specification
1		Not used
6	GND	CAN-GND, directly coupled to GND in the servo drive
2	CANL	CAN low signal line
7	CANH	CAN high signal line
3	GND	See pin no. 6
8		Not used
4		Not used
9		Not used
5	Shield	Connector for the cable shield

\*) To terminate the CAN bus at both ends, an external terminating resistor is required.

### › Cable type and configuration [X4]

The cable names that are stated refer to cables made by Lapp. However, it is also possible to use comparable cables from other manufacturers, for example Lütze or Helukabel.

**Technical data of the CAN bus cable:** 2 pairs of 2 twisted cores,  $d \geq 0.22 \text{ mm}^2$ , shielded, loop resistance  $< 0.2 \Omega/\text{m}$ , characteristic impedance 100-120  $\Omega$

LAPP KABEL UNITRONIC BUS CAN; 2 x 2 x 0.22; 7.6 mm, with CU shielding

**For highly flexible applications:**

LAPP KABEL UNITRONIC BUS CAN FD P; 2 x 2 x 0.25; 8.4 mm, with CU shielding

## 5.13 Connector: I/O interface [X1]

The BL 4000-C servo drive has two differential inputs (AIN) for analogue input voltages in the range of  $\pm 10$  V. The inputs AIN and #AIN are connected to the control system via twisted cables (twisted-pair type). Alternatively, it is also possible to use a shielded cable.

If the control system is equipped with single-ended outputs, the output is connected to AIN and #AIN is connected to the reference potential of the control system. If the control system is equipped with a differential output, it must be connected 1:1 to the differential inputs of the servo drive.

The reference potential GND24 must be connected to the reference potential of the control system. This is necessary in order to prevent the differential input of the servo drive from being overridden by high "common-mode interference".

Despite the differential design of the analogue input, using unshielded cables for the analogue signals is not recommended, since interferences, e.g. caused by switching contactors, or output stage interferences of the converters can reach high amplitudes.

The 24 V connections inside the control cabinet can be made without a shield. In the case of long cables ( $l > 2$  m) towards the PLC or outside the control cabinet, shielded cables must be used. The shields of these cables must be connected to PE on both ends. The cable shield can then be connected to the back panel of the control cabinet, for example.

For optimal interference suppression on the analogue signal lines, the cores for the analogue signal must be shielded separately. It may be useful to run the analogue signal in a separate, shielded cable.

The servo drive provides an auxiliary voltage of 24 V. As a result, the inputs can be activated directly via switches.

The digital outputs are designed as so-called "high-side switches". This means that only these 24 V are supplied to the output in the active state. In the passive state, the output has a high resistance and the level is defined only by the flyback diode and a high internal resistance.

### > Configuration on the device [X1]

D-SUB connector, 25-pin type, female

### > Mating connector [X1]

- D-SUB connector, 25-pin type, male
- Housing for a 25-pin D-SUB connector with locking screws of type 4/40 UNC

### > Pin assignment [X1]

Pin	Name	Specification
1	#AIN1	Analogue input 1, input voltage 30 V max.
14	AIN1	
2	#AIN0	Analogue input 0, input voltage 30 V max.
15	AIN0	
3	A / CLK	Incremental encoder signal A/stepper motor signal CLK
16	#A / CLK	Incremental encoder signal #A/stepper motor signal CLK
4	B / DIR	Incremental encoder signal B/stepper motor signal DIR
17	#B / DIR	Incremental encoder signal #B/stepper motor signal DIR
5	N	Incremental encoder index pulse N
18	#N	Incremental encoder index pulse #N
6	GND24	Reference potential for I/Os at [X1]
19	DIN0	Digital input 0 (target 0)
7	DIN1	Digital input 1 (target 1)
20	DIN2	Digital input 2 (target 2)
8	DIN3	Digital input 3 (target 3)
21	DIN4	Digital input 4 (input)
9	DIN5	Digital input 5 (servo drive enable signal)
22	DIN6	Digital input 6 (limit switch 0)
10	DIN7	Digital input 7 (limit switch 1)
23	DIN8	Input (flying saw)
11	5 V	Encoder supply (see pin 3 to 18)
24	24 V	Auxiliary voltage for I/Os at [X1]
12	DOUT0	Freely programmable digital output
25	DOUT1	Freely programmable digital output
13	DOUT2	Freely programmable digital output

### > Cable type and configuration [X1]

The cable name that is stated refers to a cable made by Lapp. However, it is also possible to use comparable cables from other manufacturers, for example Lütze or Helukabel.

LAPP KABEL UNITRONIC LiYCY (TP); 25 x 0.25mm<sup>2</sup>

## 5.14 Connector: STO [X3]

### **⚠ DANGER** ⚠ **Dangerous electrical voltage!**

Use only PELV circuits for the STO wiring!

Make sure that no jumpers or the like can be inserted parallel to the safety wiring. For example, use the maximum wire cross-section of 1.5 mm<sup>2</sup> or suitable wire end sleeves with insulating collars for the connection to the associated connector.

### › Configuration on the device [X3]

SC 3.81/08/90F 3.2SN BK BX

### › Mating connector

BCF 3.81/08/180F SN BK BX

### › Pin assignment [X3]



Figure 23: STO connector [X3]

Pin	Name	Description
1	STOA	Control input A for the STO function
2	GNDA	Reference potential for STOA
3	STOB	Control input B for the STO function
4	GNDB	Reference potential for STOB
5	DIN6	Connected to X1, pin 22
6	DIN7	Connected to X1, pin 10
7	DOUT0	Connected to X1, pin 12
8	GND	Reference potential for the auxiliary supply voltage

To ensure the STO ("Safe Torque Off") function, the control inputs STOA and STOB must be connected in a dual-channel manner with parallel wiring. See section *Safe torque off (STO)* in the Product manual smartServo BL 4000-C. This type of connection can be part of an emergency stop circuit or safety door setup, for example.

### › Cable type and configuration [X3]

Characteristic	Value
Max. cable length, unshielded	30 m
Max. cable length, shielded	> 30 m
Shielding	In the case of wiring outside the control cabinet and with cable lengths > 30 m, the shield must be led into the control cabinet.
Cable cross-section (flexible conductors, wire end sleeve with insulating collar), one conductor	0.25 mm <sup>2</sup> ... 0.5 mm <sup>2</sup>

### › Minimum wiring for commissioning [X3]

#### **⚠ DANGER** Danger to life due to bypassed safety functions

Safety functions must never be bypassed.

For the commissioning of the system without any safety systems, STOA and STOB can be connected to the 24 V supply and GNDA and GNDB can be connected to GND in a fixed manner.

Perform the minimum wiring of the inputs STOA/STOB and GNDA/GNDB for the commissioning process in such a way that it must be removed when the final safety wiring is performed.

## 6 Technical data

This chapter provides all of the relevant technical data of the BL 4000-C servo drives with an integrated "Safe Torque Off (STO)" safety function.

### 6.1 General technical data

#### › Qualification

Characteristic	Value
Low Voltage Directive	2014/30/EU by applying the harmonised standard EN 61800-5-1 See section 9.1 <i>CE conformity (EMC, RoHS, Low Voltage Directive)</i> on page 80
EMC	2014/35/EU by applying the harmonised standard EN 61800-3 See section 9.1 <i>CE conformity (EMC, RoHS, Low Voltage Directive)</i> on page 80 and section 5.1 <i>Notes concerning the safe and EMC-compliant installation</i> on page 24
Machinery Directive/ Functional Safety	2006/42/EC See section 9.2 <i>CE conformity (Machinery Directive)</i> on page 82
UL	Listed according to UL 61800-5-1, C22.2 No. 274-13 See section 9.3 <i>cULus certification</i> on page 86 and section 5.2 <i>Additional requirements for the UL approval</i> on page 27

#### › Ambient conditions

Characteristic	Value
Storage temperature	-25°C to +70°C
Ambient temperature	0°C to +40°C +40°C to +50°C with a power reduction of 2.5%/K
Permissible installation altitude	Max. installation altitude 2,000 m above MSL; with a power reduction of 1% per 100 m as of 1,000 m above MSL
Atmospheric humidity	Relative humidity up to 90%, non-condensing
Type of enclosure	IP20
Protection class	I
Pollution degree rating	2
Operational environment according to EN 61800-3	Without additional measures: BL 4100-C: First and second environment (C2/C3) BL 4300-C: Second environment (C3)

**INFORMATION** Compliance with the pollution degree rating

The integrated safety technology requires compliance with pollution degree rating 2 and thus a protected enclosure (IP54). This must always be ensured through appropriate measures, e.g. through installation in a control cabinet.

**⚠ WARNING** Use in residential environment

In a residential environment, servo drives of the BL 4000-C device family can cause high-frequency interference, which makes interference suppression measures necessary.

**NOTICE** Use in the public low voltage network

BL 4300-C servo drives are not suitable for use in a public low-voltage network that supplies residential areas.

**> Dimensions and weight <sup>\*)</sup>**

Characteristic	BL 4100-C	BL 4300-C
Dimensions including the mounting plate (H*W*D)	245 mm*50 mm*163 mm	275 mm*67 mm*200 mm
Housing dimensions (H*W*D)	200 mm*50 mm*163 mm	230 mm*67 mm*200 mm
Weight	approx. 1.5 kg	approx. 2.9 kg

<sup>\*)</sup> Device dimensions without the mating connector.

## 6.2 BL 4100-C: Power supply [X9]

### > Power data

Characteristic	BL 4102-C	BL 4104-C
Supply voltage	1 x 75 ... 230 VAC [ $\pm 10\%$ ], 50 ... 60 Hz	
Supply network type	TN, TT	
Maximum mains current in continuous operation (S1) * <sup>1)</sup>	3 A <sub>eff</sub>	6 A <sub>eff</sub>
DC bus voltage	325 VDC (with U <sub>mains</sub> = 230 VAC)	
24 V supply	24 VDC [ $\pm 20\%$ ] (0.35 A) * <sup>2)</sup>	

\*<sup>1)</sup> with a supply voltage of 230 V and power factor 0.6

\*<sup>2)</sup> plus the current consumption of the I/Os and a possibly existing holding brake.

#### **INFORMATION** Supply with low voltage

If low-voltage operation is necessary, we recommend using a series transformer or isolating transformer for decreasing the voltage.

#### **NOTICE** DC supply

The BL 4000-C servo drives cannot be supplied with DC voltage via the DC link terminals nor via L1/N or L1/L2/L3 (DC supply).

### > Internal braking resistor

Characteristic	Value
Braking resistor	75 $\Omega$
Peak power	2 kW
Continuous power	8 W

### > External braking resistor

Characteristic	Value
Braking resistor	$\geq 75 \Omega$
Nominal power	$\geq 8 \text{ W}$
Peak power	$\geq 2,5 \text{ kW}$
Operating voltage	$> 500 \text{ VDC}$

#### **INFORMATION** Additional information

The external braking resistor must be connected in parallel to the internal braking resistor. As a result, the continuous power and pulse power can be doubled if a 75  $\Omega$  resistor is used.



## 6.3 BL 4300-C: Power supply [X9], [X9A], [X9B]

### > Power data

Characteristic	BL 4304-C	BL 4308-C	BL 4312-C
Supply voltage	3 x 230 ... 480 VAC [ $\pm 10\%$ ], 45 ... 66 Hz		
Supply network type	TN, TT		
Maximum mains current in continuous operation (S1) <sup>*1)</sup>	4 A <sub>eff</sub>	8 A <sub>eff</sub>	12 A <sub>eff</sub>
DC bus voltage	565 VDC (with U <sub>mains</sub> = 400 VAC)		
24 V supply	24 VDC [ $\pm 20\%$ ] (0,35 A) <sup>*2)</sup>	24 VDC [ $\pm 20\%$ ] (0,45 A) <sup>*2)</sup>	24 VDC [ $\pm 20\%$ ] (0,65 A) <sup>*2)</sup>

<sup>\*1)</sup> with a supply voltage of 400 V and power factor 0.6

<sup>\*2)</sup> plus the current consumption of the I/Os and a possibly existing holding brake.

#### **INFORMATION** Supply with low voltage

If low-voltage operation is necessary, we recommend using a series transformer or isolating transformer for decreasing the voltage.

#### **NOTICE** DC supply

The BL 4000-C servo drives cannot be supplied with DC voltage via the DC link terminals nor via L1/N or L1/L2/L3 (DC supply).

### > Internal braking resistor

Characteristic	Value
Braking resistor	30 $\Omega$
Peak power	24 kW
Continuous power	50 W

### > External braking resistor

Braking resistors with the following characteristics can be connected.

Characteristic	Value
Braking resistor	$\geq 30 \Omega$
Nominal power	$\geq 100 \text{ W}$
Peak power	$\geq 24 \text{ kW}$
Operating voltage	$\geq 850 \text{ VDC}$

## 6.4 BL 4100-C: Motor connector [X6]

### > Performance data

With supply voltage 230 VAC [ $\pm 10\%$ ], 50 Hz,  $f_{\text{PWM}} = 10\text{ kHz}$ ,  $f_{\text{el}} > 2\text{ Hz}$

Characteristic	BL 4102-C	BL 4104-C
Nominal output power	400 W	800 W
Maximum output power for 2 s	1 kW	2 kW
Nominal output current	2 A <sub>eff</sub>	4 A <sub>eff</sub>
Max. output current for 2 s	6 A <sub>eff</sub>	12 A <sub>eff</sub>
Power loss/efficiency <sup>*)</sup>	5 % / 95 %	

<sup>\*)</sup> As a guide value for the control cabinet cooling system.

### > Current derating

The BL 4100-C series servo drives have a current derating during nominal operation. The rated current and the duration of the maximum permissible peak current of the servo drive depend on several factors. These factors are:

- Output current level: The higher the output current is, the shorter the permissible time will be.
- Clock frequency of the power output stage: The higher the clock frequency is, the shorter the permissible time will be.
- Rotational frequency of the motor: The lower the rotational frequency is, the shorter the permissible time will be.

The current derating begins as of a PWM frequency of 10 kHz ( $f_{\text{PWM}}$ ) and is linear between the reference values that are stated in the following table:

PWM frequency $f_{\text{PWM}}^*)$	BL 4102-C		BL 4104-C	
	I <sub>nominal</sub>	I <sub>max</sub>	I <sub>nominal</sub>	I <sub>max</sub>
10 kHz	2 A	6 A	4 A	12 A
16 kHz	1.5 A	4.5 A	3 A	9 A

<sup>\*)</sup> The PWM frequency is the reciprocal of half of the current controller cycle time  $t_c$ . The variable cycle times enable particularly high dynamics combined with reduced power data.

The maximum overload time is also subject to derating as a function of the rotational frequency (= rotational speed \* number of pole pairs). It begins with values below 2 Hz and is linear up to 0.

$f_{\text{el}}$	$t_{\text{max}}$
0	200 ms
$\geq 2\text{ Hz}$	2 s

### > Motor cable requirements

Characteristic	Value
Cable length	$l \leq 25 \text{ m}$ See section 5.1 <i>Notes concerning the safe and EMC-compliant installation</i> on page 24
Cable capacity	$C' \leq 160 \text{ pF/m}$ of one phase against shield or between two lines

### > Motor temperature monitoring system

#### **⚠ DANGER** ⚠ **Dangerous electrical voltage!**

The signals for the temperature sensor "MT-" and "MT+" at the motor connector [X6] must be connected to protective extra-low voltage (PELV) on the motor side and they must be insulated against the motor phases.

#### **NOTICE** **Electronic overload protection of the motor**

The servo drive has an electronic cut-out for overload protection combined with thermal memory retention. For an effective protection, the nominal motor current, maximum motor current and overload time ( $I^2t$  time) must be parameterised as described in the product manual.

Characteristic	Value
Sensor type	Analogue
Sensor type	Silicon temperature sensor PTC/NTC, e.g. KTY84-130 or similar
Characteristic curve	Linear/non-linear, parameterisable (10 nodes)
Measuring range	from 300 $\Omega$ to 20 k $\Omega$ (+-10%)
Output voltage	+ 3.3 V
Output current	1.7 mA max. (via 2 k $\Omega$ measuring resistor)
Internal resistance	approx. 2 k $\Omega$

### > Output for the holding brake in the motor

Characteristic	Value
Nominal voltage	24 V
Nominal current	2 A (total of all digital outputs and of the holding brake: 2.5 A max.)
Voltage drop referred to the 24 V input with a load current of 2 A	approx. 1.5 V
Overload protection	Yes, current limitation to 3 A max.
Overvoltage protection	up to 60 V
Internal flyback diode	Yes

**> HIPERFACE DSL<sup>®</sup> connector [X6]**

Characteristic	Value
HPF_DSL-, HPF_DSL+	In accordance with the HIPERFACE DSL <sup>®</sup> specification RS485
Baud rate	9.37 MHz
Frame rate	12.1 to 27 $\mu$ s
Supply voltage	10 V (250 mA)
Supported transfer modes	Transfer of short and long messages with storage of the set of parameters in the encoder
Characteristic impedance of the cable and line termination	110 $\Omega$

## 6.5 BL 4300-C: Motor connector [X6], [X6A]

### > Performance data

Supply voltage 400 VAC [ $\pm 10\%$ ], 50 Hz,  $f_{PWM} = 8 \text{ kHz}$ ,  $f_{el} > 3 \text{ Hz}$

Characteristic	BL 4304-C	BL 4308-C	BL 4312-C
Nominal output power	1,6 kW	3,2 kW	4,8 kW
Maximum output power for 2 s	4,8 kW	9,6 kW	12 kW
Nominal output current	4 A <sub>eff</sub>	8 A <sub>eff</sub>	12 A <sub>eff</sub>
Max. output current for 2 s	12 A <sub>eff</sub>	24 A <sub>eff</sub>	30 A <sub>eff</sub>
Power loss/efficiency <sup>*)</sup>	5 % / 95 %		

<sup>\*)</sup> As a guide value for the control cabinet cooling system.

### > Current derating

The BL 4300-C series servo drives have a current derating during nominal operation. The rated current and the duration of the maximum permissible peak current of the servo drive depend on several factors. These factors are:

- Output current level: The higher the output current is, the shorter the permissible time will be.
- Clock frequency of the power output stage: The higher the clock frequency is, the shorter the permissible time will be.
- Rotational frequency of the motor: The lower the rotational frequency is, the shorter the permissible time will be.

The current derating begins as of a PWM frequency of 8 kHz ( $f_{PWM}$ ) and is linear between the reference values that are stated in the following table:

PWM frequency $f_{PWM}^*)$	BL 4304-C		BL 4308-C		BL 4312-C	
	I <sub>nominal</sub>	I <sub>max</sub>	I <sub>nominal</sub>	I <sub>max</sub>	I <sub>nominal</sub>	I <sub>max</sub>
8 kHz	4 A	12 A	8 A	24 A	12 A	30 A
16 kHz	2.5 A	7.5 A	5 A	15 A	7.5 A	18.8 A

<sup>\*)</sup> The PWM frequency is the reciprocal of half of the current controller cycle time  $t_i$ . The variable cycle times enable particularly high dynamics combined with reduced power data.

The maximum overload time is also subject to derating as a function of the rotational frequency (= rotational speed \* number of pole pairs). It begins with values below 3 Hz and is linear up to 2 Hz.

Rotational frequency $f_{el}$	BL 4304-C	BL 4308-C	BL 4312-C
	t <sub>max</sub>	t <sub>max</sub>	t <sub>max</sub>
< 2 Hz	100 ms	100 ms	50 ms
>= 3 Hz	2 s	2 s	2 s

### › Motor cable requirements

Characteristic	Value
Cable length	$l \leq 25 \text{ m}$ See section 5.1 <i>Notes concerning the safe and EMC-compliant installation</i> on page 24
Cable capacity	$C' \leq 160 \text{ pF/m}$ of one phase against shield or between two lines

### › Motor temperature monitoring system

#### **⚠ DANGER** ⚠ **Dangerous electrical voltage!**

The signals for the temperature sensor "MT-" and "MT+" at the motor connector [X6] must be connected to protective extra-low voltage (PELV) on the motor side and they must be insulated against the motor phases.

#### **NOTICE** **Electronic overload protection of the motor**

The servo drive has an electronic cut-out for overload protection combined with thermal memory retention. For an effective protection, the nominal motor current, maximum motor current and overload time ( $I^2t$  time) must be parameterised as described in the product manual.

Characteristic	Value
Sensor type	Analogue
Sensor type	Silicon temperature sensor PTC/NTC, e.g. KTY84-130 or similar
Characteristic curve	Linear/non-linear, parameterisable (10 nodes)
Measuring range	from $300 \Omega$ to $20 \text{ k}\Omega$ (+-10%)
Output voltage	+ 3.3 V
Output current	1.7 mA max. (via $2 \text{ k}\Omega$ measuring resistor)
Internal resistance	approx. $2 \text{ k}\Omega$

### › Output for the holding brake in the motor

Characteristic	Value
Nominal voltage	24 V
Nominal current	2 A (total of all digital outputs and of the holding brake: 2.5 A max.)
Voltage drop referred to the 24 V input with a load current of 2 A	approx. 1.5 V
Overload protection	Yes, current limitation to 3 A max.
Overvoltage protection	up to 60 V
Internal flyback diode	Yes

### › HIPERFACE DSL<sup>®</sup> connector [X6]

Characteristic	Value
HPF_DSL-, HPF_DSL+	In accordance with the HIPERFACE DSL <sup>®</sup> specification RS485
Baud rate	9.37 MHz
Frame rate	12.1 to 27 $\mu$ s
Supply voltage	10 V (250 mA)
Supported transfer modes	Transfer of short and long messages with storage of the set of parameters in the encoder
Characteristic impedance of the cable and line termination	110 $\Omega$

## 6.6 Resolver connector [X2A]

Characteristic	Value
Transformation ratio	1:2 to 1:4
Carrier frequency	5-10 kHz
Excitation voltage	5-6 V <sub>eff</sub> , short-circuit-proof
Excitation impedance (at 10 kHz)	4 $\Omega$
Stator impedance	> 30 $\Omega$
Measuring range (for Hall sensors)	7 V <sub>ss</sub>
Resolution	14 bits
Signal detection delay	< 200 $\mu$ s
Speed resolution	approx. 5 rpm
Actual speed value filter	400 $\mu$ s
Absolute angle detection accuracy	< 0.022°
Max. speed	16,000 rpm

## 6.7 Encoder connector [X2B]

The correct parameterisation of the multi-encoder interface is described in section „X2B/X6“ tab in the Product manual smartServo BL 4000-C.

### **INFORMATION** Possibly not all encoders of a manufacturer are supported

It is possible that not all encoders of a manufacturer are fully supported. In individual cases it is therefore always recommended to test the encoder in advance in the intended application.

### ➤ Power supply output

The power supply for the encoders can be changed.

### **NOTICE** Risk of destruction due to excessive voltage

If the voltage is too high, the angle encoder may be destroyed. Ensure that you have selected the correct supply voltage prior to connecting the encoder to the [X2B] connector.

Characteristic	Low voltage	High voltage
Output voltage	5.4 V	10.4 V
Output current	250 mA	200 mA
Short-circuit strength	Yes	Yes
Control via sense leads	Yes	Yes

### ➤ Digital incremental encoders

Digital incremental encoders with RS422-compatible A/B/N signals with a line count of up to 16,384 lines can be connected (e.g. ERN 420). In addition, Hall generator signals with a TTL level for determining the commutation position can also be connected.

Characteristic	Value
Parameterisable number of encoder lines	1 to 2 <sup>18</sup> lines/revolution
Track signals A, B (Z0 track)	In accordance with RS422 Input 0.4 V with a common-mode level of -0.3 to 5 V
Track signal N (index pulse)	In accordance with RS422 Input 0.4 V with a common-mode level of -0.3 to 5 V
Hall generator input	TTL level (<0.5 V = Low, > 2 V = Hi) 2 kΩ pull-up
Error input (AS/NAS)	TTL level (<0.5 V = Low, > 2 V = Hi) 2 kΩ pull-up
Track signal input impedance	Differential input 120 Ω
Limit frequency	10 MHz



### > Analogue incremental encoders with commutation signals

Analogue incremental encoders with RS422-compatible 1 V<sub>SS</sub> signals (e.g. ERN 1387) can be connected.

Characteristic	Value
Parameterisable number of encoder lines	1 to 2 <sup>18</sup> lines/revolution
High position resolution of the AB track (Z0) and commutation track (Z1)	12 bits/period
Track signals A, B (Z0 track)	1.2 V <sub>SS</sub> differential
Track signal N (index pulse) switching threshold	0.1 V <sub>SS</sub> differential
Commutation track (Z1 track)	1.2 V <sub>SS</sub> differential
Error input (AS/NAS)	TTL level (<0.5 V = Low, > 2 V = Hi) 2 kΩ pull-up
Track signal input impedance	Differential input 120 Ω
Z0 track limit frequency	f <sub>limit</sub> > 300 kHz
Z1 track limit frequency	f <sub>limit</sub> approx. 10 kHz (commutation track)

### > HIPERFACE<sup>®</sup> encoders

Shaft encoders with HIPERFACE<sup>®</sup> made by Sick-Stegmann are supported in the single-turn and multi-turn variants. The following encoder models can be connected:

- Single-turn SinCos encoders: SCS 60/70, SKS 36, SRS 50/60/64, SEK 34/37/52
- Multi-turn SinCos encoders: SCM 60/70, SKM 36, SRM 50/60/64, SEL 34/37/52
- Single-turn SinCos encoders for hollow shaft drives: SCS-Kit 101, SHS 170, SCK 25/35/40/45/50/53
- Multi-turn SinCos encoders for hollow shaft drives: SCM-Kit 101, SCL 25/35/40/45/50/53

In addition, the following Sick-Stegmann encoder systems can be connected and evaluated:

- Absolute, non-contact length measuring systems L230 and TTK70 (HIPERFACE®)
- Digital incremental encoder CDD 50

Characteristic	Value
Parameterisable number of encoder lines	Depending on the encoder
Track signals A, B (Z0 track)	As per RS485 Input: 0.4 V, output: 0.8 V to 2 V
Hall generator input	TTL level (<0.5 V = Low, > 2 V = Hi) 2 kΩ pull-up
Error input (AS/NAS)	TTL level (<0.5 V = Low, > 2 V = Hi) 2 kΩ pull-up
Track signal input impedance	Differential input 120 Ω
Limit frequency	Up to 10 MHz, depending on the encoder system
Supported operating modes	Storage of the parameter set in the encoder in the case of Endat and HIPERFACE®

Angle encoders made by Sick with the HIPERFACE DSL® interface (e.g. EKM36) are also supported. They must be connected to X6. See section 6.4 *BL 4100-C: Motor connector [X6]* on page 58 or section 6.5 *BL 4300-C: Motor connector [X6], [X6A]* on page 61.

### › EnDat encoders

Incremental and absolute encoders by Heidenhain with the ordering code ENDAT22 can be evaluated. The following encoder models can be connected:

- Analogue incremental encoders: ROD 400, ERO 1200/1300/1400, ERN 100/400/1100/1300
- Single-turn encoders (ENDAT22): ROC 425, ECI 119/1118/1319, ECN 125/425/1023
- Multi-turn encoders (ENDAT22): ROQ 437/1035, EQI 1131/1331, EQN 437/1035/1135/1337
- Absolute length measuring systems (ENDAT22): LC 115/415
- Battery-buffered encoders (ENDAT22): EBI 135/1135/4010
- Angle encoder modules (ENDAT22): MRP 2010/5010/8010

### › BiSS encoders®

Type C BiSS encoders are supported. The evaluation of the internal type plate, however, is not supported. The storage of data in the encoder is not possible.

Encoders made by Hengstler, Kübler and Balluff are supported.

## 6.8 USB [X19]

Communication interface	Value
Function	USB 2.0, USB-B, slave-client
Connector type	USB-B
Current consumption	None (self-powered)
Protocol	Manufacturer-specific (generic device)

## 6.9 Standard Ethernet [X18]

Communication interface	Value
Function	Ethernet, 10/100 Mbaud, UDP communication
Connector type	RJ45
Protocol	TCP/IP

## 6.10 Realtime-Ethernet [X21]

At present, the servo drives of the BL 4000-C series support the following fieldbuses and application protocols

Fieldbus	Profile
PROFINET	Manufacturer-specific protocol (based on PROFIdrive V3.1)
EtherCAT	CoE (Can over EtherCAT)

The support of these fieldbus types is integrated in the servo drive. Additional modules are not required. The parameterisation is performed with the aid of the MPC ServoCommander. For further information about the fieldbus connection, see the fieldbus-specific product manuals section 1.2 *Additional documents* on page 6).

Suitable GSDML (PROFINET) and XML (EtherCAT) files for the integration of the fieldbus slave into the environment of an external control system can be found at our homepage (<https://www.motorpowerco.com>).

## 6.11 CAN bus [X4]

Suitable EDS files for the integration of the fieldbus slave into the environment of an external control system can be found at our homepage (<https://www.motorpowerco.com>).

Communication interface	Value
Standard	ISO/DIS 11898-2, CAN 2 0A
Baud rates	50, 100, 125, 250, 500, 1000 kbit/s
Protocol	CANopen, as per DS301 and DSP402

## 6.12 I/O Interface [X1]

Servo drives of the BL 4000-C series have 3 digital outputs (DOUT), 9 digital inputs (DIN) and 2 analogue inputs (AIN).

### > Digital outputs

Characteristic	Value
Nominal voltage	24 V
Output current	Approx. 1 A per output, but 2.5 A max. in total, including the brake output

### > Digital inputs

Characteristic	Value
Nominal voltage	24 V as per DIN EN 61131-2 (< 10 V low, >15..30 V high)
Current consumption	3.2 mA max.

The mode of operation of the digital inputs can be configured to a large extent. The default setting is stated in brackets.

Characteristic	Value	Filter time	Max. jitter
DIN0...DIN3	Freely configurable (position selector)	4 x $t_x$ *)	1 x $t_x$
DIN4	Freely configurable (positioning start)	4 x $t_x$	1 x $t_x$ , (15 ns for sampling)
DIN5	Controller enable signal	4 x $t_x$	1 x $t_x$
DIN6, DIN7	Limit switch 0, 1	4 x $t_x$	1 x $t_x$
DIN8	Freely configurable (sampling, flying saw)	4 x $t_x$	1 x $t_x$ , (15 ns for sampling)

\*)  $t_x$  corresponds to the configurable position controller cycle time

### > Analogue input AIN0

Characteristic	Value
Input range	$\pm 10$ V
Resolution	12 Bit
Filter time	configurable: 2 x $t_f$ to 200 ms

\*)  $t_f$  corresponds to the configurable current controller cycle time

### › Analogue input AIN1

Characteristic	Value
Input range	$\pm 10$ V
Resolution	12 bits
Filter time	$4 \times t_i$

\*)  $t_i$  corresponds to the configurable current controller cycle time

### › Master frequency input [X1]

This input cannot only be used for the connection of the master frequency output of another BL 4000-C , BL 4000-M / BL 4000-D. It can also be used for the connection of encoders as per the RS422 industry standard or of encoders with "single-ended" TTL output or "open-collector" outputs. If TTL encoders are used, it must be taken into consideration that the hysteresis is negligible. In addition, the requirements concerning the signal shield must be fulfilled.

As an alternative, the A and B track signals of the device are interpreted as pulse direction signals by the device so that the servo drive can also be controlled by stepper motor control boards.

Ensure the correct configuration of the interface. This is important since the master frequency input can also be used as the master frequency output.

Characteristic	Value
Parameterisable line count	1 to $2^{28}$ lines/revolution
Track signals A, B, N	As per the RS 422 specification
Special feature	N track can be deactivated
Maximum input frequency	10 MHz
Filtering	Quadruple oversampling
Supply output	5 V, 200 mA, short-circuit-proof – not overvoltage-proof

### › Master frequency output [X1]

The connector [X1] also accommodates the master frequency output (encoder emulation). To use this function, [X1] must be configured as the master frequency output.

Characteristic	Value
Number of lines	Programmable 1 to $2^{16}$ lines/revolution
Track signals A, B, N	As per the RS422 specification
Special feature	N track can be deactivated
Limit frequency	$f_{\text{limit}} > 10$ MHz

The signals are generated based on the angle of rotation of the encoder with a freely programmable line count.

In addition to the track signals A and B, the master frequency output also provides an index pulse. Once per revolution, this index pulse turns high (for the programmed number of lines) for half of a signal period.

Please also note that the track signals will not be automatically output with a constant frequency. They may also be generated as so-called "pulse packets" depending on the

covered rotational angle of the source. This means that the interface for any downstream circuits must be suitable for incremental encoders. As a result, the measurement of gate times or the analysis of the time between two lines for determining a speed value is possible only to a limited extent.

## 6.12.1 Time response of the digital inputs

The digital inputs are digitally filtered to improve the interference suppression. The following illustration shows the filter time mechanism. In addition, the special reaction to the "Positioning start" function is also shown. Although the signal is evaluated during the position controller cycle  $t_x$  the start of a movement will be performed within the interpolation cycle time matrix  $t_p$ .

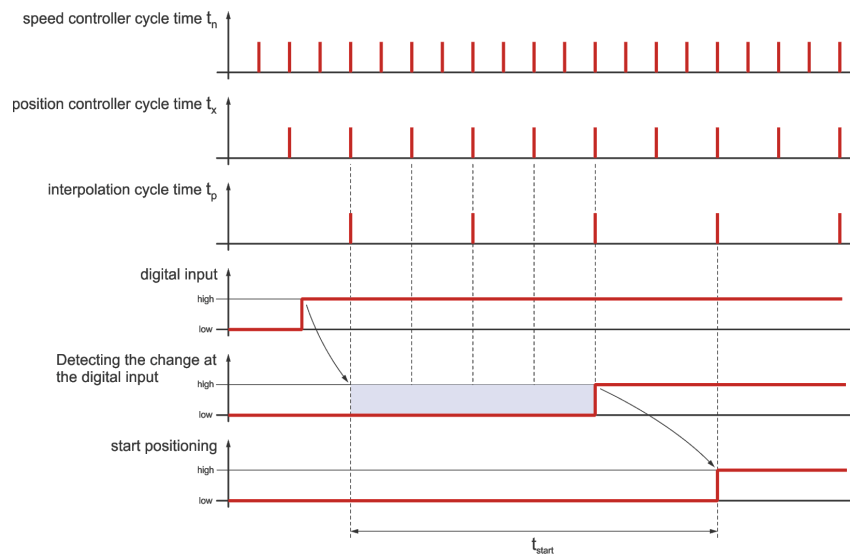

Figure 24: Filter time mechanism in the case of digital inputs

Parameter	Max.
Maximum delay until the start of a position set becomes active $t_{start}$	$5 \cdot t_x + t_p$
Current rise time (with current feedforward control)	$t_n + t_i + t_{pwm}$

$t_i$  = Current controller cycle time (typically 50  $\mu$ s )

$t_x$  = position controller cycle time (typically 200  $\mu$ s with a current controller cycle time  $t_i$  of 50  $\mu$ s)

$t_n$  = speed controller cycle time (typically 100  $\mu$ s with a current controller cycle time  $t_i$  of 50  $\mu$ s)

$t_{pwm}$  = half the cycle time of the PWM (corresponds to  $t_i$ )

## 6.12.2 Time response of the digital outputs

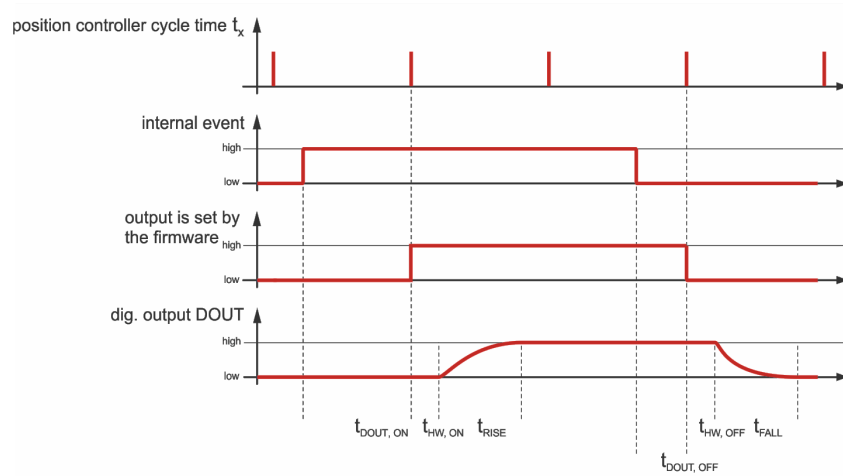

Figure 25: Filter time mechanism in the case of digital outputs

Parameter	Value
Delay caused by the firmware $t_{DOUT\_ON}/t_{DOUT\_OFF}$	$t_x$
DOUT $t_{HW, ON}$	typically 100 $\mu$ s
DOUT $t_{HW, OFF}$	typically 300 $\mu$ s
$t_{RISE}$	typically 100 ms with 2 A and inductive load
$t_{FALL}$	typically 100 ms with 2 A and inductive load

$t_x$  = position controller cycle time (typically 200  $\mu$ s with a current controller cycle time  $t_i$  of 50  $\mu$ s)

### 6.12.3 Time response during power ON

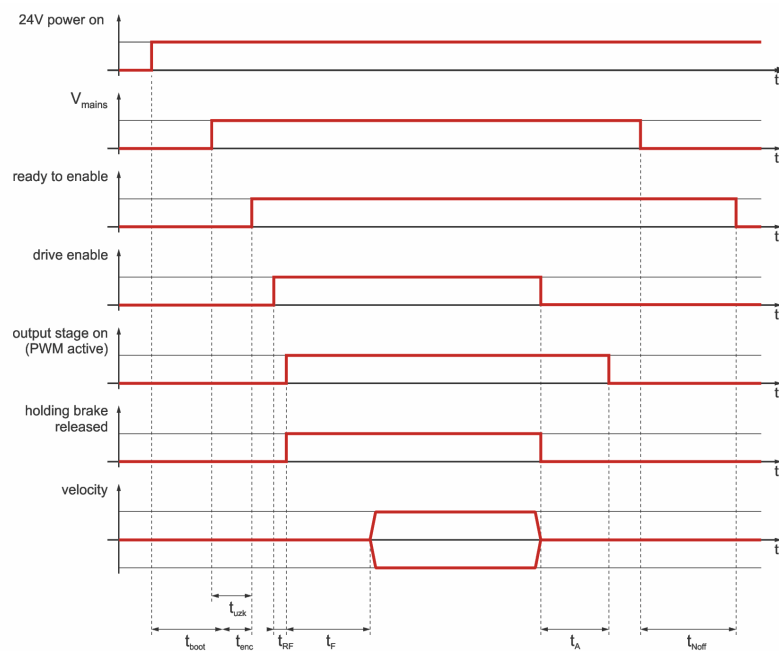

Figure 26: Time diagram of the servo drive

Parameter	Min.	Typ.	Max.
Start of the firmware after power ON $t_{boot}$			4 s
Encoder start time $t_{enc}$	0.7 s (resolver)		2 s (HIPERFACE DSL®)
DC bus charging time $t_{UZK}$		1 s	
Output stage active after servo drive enabling $t_{RF}$		6 ms	
Movement start delay $t_F$ (parameterisable)	0		32 s
Stop delay $t_A$ (parameterisable)	0		32 s
Detection of mains power OFF $t_{Noff}$		0.6 s	



## 6.13 STO [X3]

### > Characteristic values

Characteristic	Value
Safety level	Category 4 and performance level e or SIL3/SIL CL3.
PFH (probability of dangerous failure per hour)	$3 \times 10^{-11}$
PFD (probability of dangerous failure on demand)	$5 \times 10^{-6}$
DCavg (average diagnostic coverage)	High
MTTFd (mean time to dangerous failure)	Limited to 100 years (cat. 3) Limited to 2,500 years (cat. 4)

See also section 9.2 *CE conformity (Machinery Directive)* on page 82.

#### **INFORMATION** Proof-testing of the STO function

Comply with the following test intervals in order to reach the specified values:

- For SIL 2, PL d/category 3: 1x per year
- For SIL 3, PL e/category 3: every 3 months
- For SIL 3, PL e/category 4: daily

### 6.13.1 Electrical data of the STO function

#### > Control inputs STOA/STOB [X3]

Characteristic	Value
Nominal voltage	24 V (referred to GNDA/GNDB)
Voltage range	19.2 V... 28.8 V
Permissible ripple	2 % (referred to a nominal voltage of 24 V)
Nominal current	20 mA typ., 30 mA max.
Switch-on input voltage threshold	$\geq 16 \text{ V}$
Switch-off input voltage threshold	$< 5 \text{ V}$

For the technical data of the digital inputs DIN6 and DIN7 or of the digital output DIN0, see the section 6.12 *I/O Interface [X1]* on page 68.

### › Response time until power output stage inactive and maximum OSSD test pulse duration

The typical response time and the maximum test pulse duration depend on the input voltage at STOA/STOB:

Characteristic	Value		
Input voltage (STOA/STOB)	19.2 V	24 V	28.8 V
Typical response time	2 ms	3 ms	4 ms
Max. test pulse duration (OSSD)	0.5 ms	1 ms	1.5 ms

The maximum response time  $t_{\text{STOAB/OFF}}$  is described in section 6.13.2.1 *Time response of the STO activation during operation with a restart* on page 74.

## 6.13.2 Time response

### **INFORMATION** Equal inputs in terms of their functionality

The inputs STOA and STOB are absolutely equal in terms of their functionality, which is why the switching sequence of STOA/STOB is interchangeable in all of the diagrams.

### 6.13.2.1 Time response of the STO activation during operation with a restart

The illustration shows the time response starting with the disconnection of the control voltage at STOA/B and the sequence that is necessary for restarting the device.

- The actuation of the holding brake is realised via the basic device and not in a safety-oriented manner.
- The illustration shows the coasting of the motor regardless of the activation/deactivation of the brake
- The setpoint will not be enabled until the holding brake delay  $T_F$  has elapsed.
- An error will be issued as the STO inputs are deactivated while the output stage is active. It is not included in the drawing.

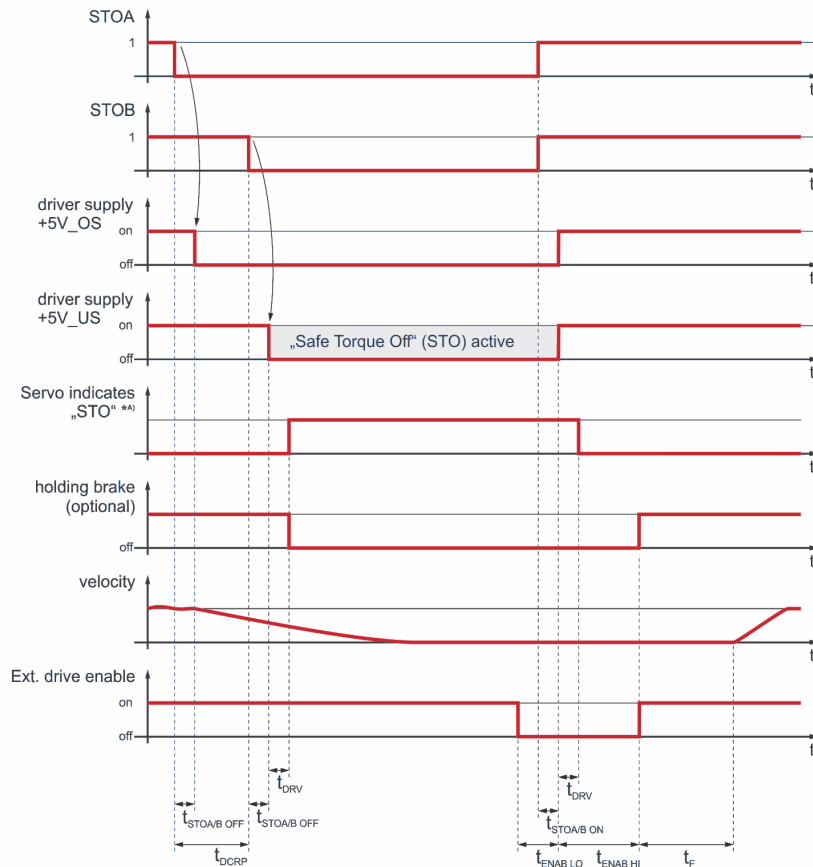

Figure 27: Time response of the activation of the STO safety function with a restart

\*A) see section *Operating mode and error indication* in the Product manual smartServo BL 4000-C

Time	Description	Value
$t_{DCRP}$	Maximum permissible discrepancy time without the servo drive issuing an error	100 ms
$t_{STOA/B\ OFF}$	STOA/B – switching time from high to low (See also section <i>Response time until power output stage inactive and maximum OSSD test pulse duration</i> on page 74)	Maximum response time 5 ms
$t_{STOA/B\ ON}$	STOA/B switching time from low to high	0.6 ms typ., 1 ms max.
$t_{DRV}$	Delay of the internal sequence control of the servo drive	10 ms max.
$t_{ENAB\ LO}$	Time that the servo drive enable signal (DIN5 or bus enable signal) must be low before STOA/B will be activated	0
$t_{ENAB\ HI}$	Time that the servo drive enable signal (DIN5 or bus enable signal) must be low after STOA/B has been reactivated and the status of the STO circuit has changed	> 20 ms
$t_F$	Brake control and automatic brake	Parameterisable <sup>1</sup>

<sup>1</sup> see section *Brake control and automatic brake* in the Product manual smartServo BL 4000-C

### 6.13.2.2 Time response of the SS1 activation during operation with a restart

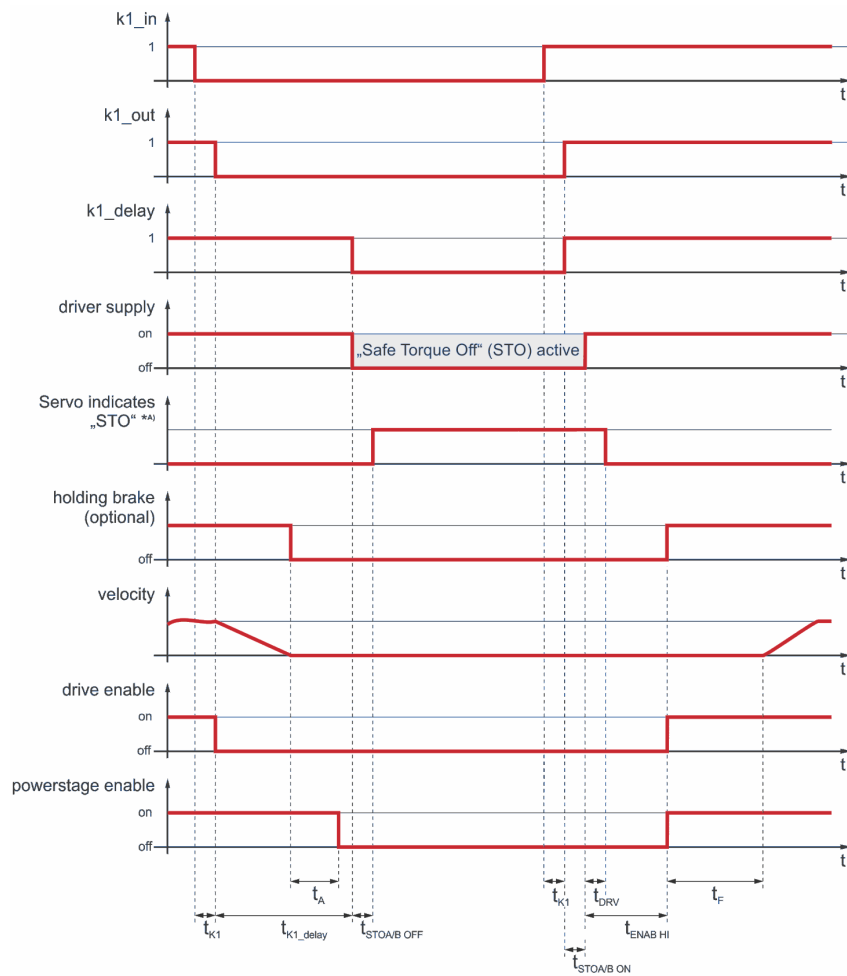

Figure 28: Time response during the activation of the SS1 safety function (external switching) with a restart

\*A) see section *Operating mode and error indication* in the Product manual smartServo BL 4000-C

Time	Description	Value
$t_{K1}$	Delay between the switching of S1 and the closing of the undelayed contact K1	See the data sheet of the safety relay
$t_{K1\_delay}$	Delay between S1 and the opening of the off-delayed contacts K1	Can be adjusted on the safety relay
$t_{STOA/B\ OFF}$	STOA/B – switching time from high to low. See also section <i>Response time until power output stage inactive and maximum OSSD test pulse duration</i> on page 74	Maximum response time 5 ms
$t_{STOA/B\ ON}$	STOA/B – switching time from high to low	0.6 ms typ., 1 ms max.
$t_{DRV}$	Delay of the internal sequence control of the servo drive	10 ms max.
$t_{ENAB\ HI}$	Time that DIN5 must be low after STOA/B has been reactivated and the status of the STO circuit has changed	> 20 ms
$t_A$	Switch-off delay of the holding brake	Parameterisable <sup>1</sup>
$t_F$	Switch-on delay of the holding brake	Parameterisable <sup>1</sup>

<sup>1</sup> see section *Brake control and automatic brake* in the Product manual smartServo BL 4000-C

## 6.14 MicroSD card

Communication interface	Value
File system	FAT16, FAT32
Connector type	microSD card
File names	Only file and folder names that comply with the 8.3 standard are supported.

# 7 Storage/transport

The following requirements must be fulfilled for the storage and transport of the servo drive:

## > Storage

- Store the servo drive in line with the specified storage temperatures. Use only its original packaging.
- After approximately six months of storage, the oxide layer of the capacitors may become damaged. This is why the servo drive must be supplied with power for approximately 1 hour every six months (24 V and 230 V) in order to preserve the oxide layer.

## > Transport

### **⚠ CAUTION** Risk of injury due to improper transport

Follow these instructions to ensure the safe transport of the servo drive and to avoid injuries.

- Use only qualified personnel for the transport of the servo drive.
- Transport the servo drive only in its original packaging.
- Use only suitable transport equipment.
- Use suitable personal protective equipment.
- If you notice that the packaging is damaged, notify the carrier without delay. Then, inspect the servo drive for any signs of external or internal damage.

## > Transport damage

### **⚠ DANGER** ⚠ Dangerous electrical voltage!

Transport damage to the servo drive may compromise the insulation between the low-voltage part and the high-voltage part. This results in an extremely dangerous electrical voltage. Do not use the servo drive in this case. The servo drive needs to be checked by the sales partner or manufacturer.

In case of external damage (dents, deformed mounting flange, etc.) it must be presumed that some of the components have come loose and the breakdown strength concerning the high-voltage part may no longer be existent.

# 8 Maintenance, cleaning, repair and disposal

The following requirements must be fulfilled for the maintenance, cleaning, repair and disposal of the servo drive:

## > Maintenance

Servo drives of the BL 4000-C device series are maintenance-free.

## > Cleaning

### **NOTICE** Damage to the servo drive due to improper cleaning

To remove surface soiling, e.g. residues of adhesive labels, the servo drive can be cleaned carefully on the outside with suitable tools. It must be absolutely ensured that liquids of any kind cannot penetrate the servo drive. Seals may be destroyed which, in turn, would lead to short circuits.

Use the servo drive in a clean environment. Soiling due to dust, oil, oil vapour, grease, fibres or similar inside the device will compromise the insulation with regard to the high-voltage part. Stop using the device immediately if this is the case.

## > Repair

Opening the device is not permissible and will render the warranty null and void. Only the manufacturer is authorised to perform repairs. Please contact your sales partner.

## > Disposal, removal, decommissioning, replacement

### **⚠ DANGER** ⚠ Dangerous electrical voltage!

Following the instructions stated hereinbelow to ensure the safe decommissioning of the servo drive.

- Switch the power supply completely off.
- Disconnect the mains power connectors.
- Lock the system so that it cannot be reactivated.
- Make sure that the DC bus has discharged by measuring at the DC bus terminals ZK+ and ZK- or wait for the maximum discharge time. This is for the BL 4000-C **10 minutes**. In the event of a device defect, connections other than those specified here may also carry a life-threatening voltage. Under these circumstances, the discharge time must be waited for in any case.
- Contact a sales partner in terms of a return or replacement of the device.

# 9 Appendix

## 9.1 CE conformity (EMC, RoHS, Low Voltage Directive)

### > BL 4100-C



A company of Apex Tool Group, LLC.

# 10/2022

#### EU Konformitätserklärung

#### EU Declaration of Conformity

**Metronix Meßgeräte und Elektronik GmbH, Kocherstrasse 3, 38120 Braunschweig GERMANY**

erklärt hiernit in alleiniger Verantwortung, dass die Servoregler

hereby declares under sole responsibility that the Servo drives

#### smartServo BL 410x-C

konform sind mit den Vorschriften der folgenden Richtlinien und Normen:

comply with the following directives and standards:

#### Niederspannungsrichtlinie 2014/35/EU

Angewandte harmonisierte Normen:

EN 61800-5-1:2007  
EN 61800-5-1:2007/A1:2017

#### Low Voltage Directive 2014/35/EU

Applied harmonized standards:

EN 61800-5-1:2007  
EN 61800-5-1:2007/A1:2017

#### EMV-Richtlinie 2014/30/EU

Angewandte harmonisierte Normen:

EN 61800-3:2004/A1:2012

#### EMC Directive 2014/30/EU

Applied harmonized standards:

EN 61800-3:2004/A1:2012

#### RoHS Richtlinie 2011/65/EU\*

\*inklusive aller aktuell gültigen Erweiterungen

Angewandte harmonisierte Normen:

EN IEC 63000:2018

#### RoHS Directive 2011/65/EU\*

\*including all currently valid amendments

Applied harmonized standards:

EN IEC 63000:2018

Weitere angewandte nicht harmonisierte Normen oder sonstige Spezifikationen:

Keine

More applied non-harmonized standards or specifications:

None

#### Besondere Bedingungen:

Die aufgeführten Geräte sind im Sinne der EMV-Richtlinie keine eigenständig betreibbaren Produkte. Die Einhaltung der Richtlinie setzt den korrekten Einbau der Produkte, die Beachtung der spezifischen Installationshinweise und der Produktdokumentation voraus. Dies wurde an bestimmten Anlagenkonfigurationen nachgewiesen.

#### Specific Requirements:

According to the EMC Directive, the listed devices are not independently operable products. Compliance of the directive requires the correct installation of the product, the observance of the specific installation notes and product documentation. This was tested in specific system configurations.

Diese Erklärung bescheinigt die Übereinstimmung mit den genannten Richtlinien, beinhaltet jedoch keine Zusicherung von Eigenschaften.

This declaration certifies compliance with the stated Directive but implies no warranty of properties.

Die Sicherheits- und Installationshinweise der Produktdokumentation sind zu beachten.

The safety and installation instructions of the product documentation are to be considered

Ort / Place  
Datum / Date

Braunschweig 13. Sept. 2022

Unterschrift /  
Signature:

Director Sales and Commercial  
Metronix  
Meßgeräte und Elektronik GmbH  
i. V. Olaf Donner  
Kocherstrasse 3  
38120 Braunschweig

General Manager

Walter Wehmeyer

FM 7.3.3-4 Vers. 2.1



➤ BL 4300-C



# 11/2022

**EU Konformitätserklärung**

**EU Declaration of Conformity**

**Metronix Meßgeräte und Elektronik GmbH, Kocherstrasse 3, 38120 Braunschweig GERMANY**

erklärt hiermit in alleiniger Verantwortung, dass die Servoregler

hereby declares under sole responsibility that the Servo drives

**smartServo BL 43xx-C**

konform sind mit den Vorschriften der folgenden Richtlinien und Normen:

comply with the following directives and standards:

**Niederspannungsrichtlinie**  
2014/35/EU

**Low Voltage Directive**  
2014/35/EU

Angewandte harmonisierte Normen:  
EN 61800-5-1:2007  
EN 61800-5-1:2007/A1:2017

Applied harmonized standards:  
EN 61800-5-1:2007  
EN 61800-5-1:2007/A1:2017

**EMV-Richtlinie**  
2014/30/EU

**EMC Directive**  
2014/30/EU

Angewandte harmonisierte Normen:  
EN 61800-3:2004/A1:2012  
EN IEC 61800-3:2018

Applied harmonized standards:  
EN 61800-3:2004/A1:2012  
EN IEC 61800-3:2018

**RoHS Richtlinie**  
2011/65/EU\*

**RoHS Directive**  
2011/65/EU\*

\*inklusive aller aktuell gültigen Erweiterungen  
Angewandte harmonisierte Normen:  
EN IEC 63000:2018

\*including all currently valid amendments  
Applied harmonized standards:  
EN IEC 63000:2018

**Weitere angewandte nicht harmonisierte Normen oder sonstige Spezifikationen:**

**More applied non-harmonized standards or specifications:**

Keine

None

**Besondere Bedingungen:**

**Specific Requirements:**

Die aufgeführten Geräte sind im Sinne der EMV-Richtlinie keine eigenständig betreibbaren Produkte. Die Einhaltung der Richtlinie setzt den korrekten Einbau der Produkte, die Beachtung der spezifischen Installationshinweise und der Produktdokumentation voraus. Dies wurde an bestimmten Anlagenkonfigurationen nachgewiesen.

According to the EMC Directive, the listed devices are not independently operable products. Compliance of the directive requires the correct installation of the product, the observance of the specific installation notes and product documentation. This was tested in specific system configurations.

Diese Erklärung bescheinigt die Übereinstimmung mit den genannten Richtlinien, beinhaltet jedoch keine Zusage von Eigenschaften.

This declaration certifies compliance with the stated Directive but implies no warranty of properties.

Die Sicherheits- und Installationshinweise der Produktdokumentation sind zu beachten.

The safety and installation instructions of the product documentation are to be considered

Ort / Place  
Datum / Date

*Braunschweig, 13. Sep 2022*

Director Sales and Commercial

General Manager

Unterschrift / Signature:



*Olaf Donner*  
Metronix  
Meßgeräte und Elektronik GmbH  
Tel: +49 531 38120-100  
Telefax: +49 531 38120-105  
Kocherstr. 3  
38120 Braunschweig

*W. Wehmeyer*  
Walter Wehmeyer

FM 7.3.3-4 Vers. 2.1

## 9.2 CE conformity (Machinery Directive)

### > BL 4100-C

	 <small>A company of Apex Tool Group, LLC.</small> <small># 02/2019</small>
<b>EG Konformitätserklärung</b>	<b>EC Declaration of Conformity</b>
<b>Metronix Meßgeräte und Elektronik GmbH, Kocherstrasse 3, 38120 Braunschweig GERMANY</b>	
erklärt hiermit in alleiniger Verantwortung, dass die	
hereby declares under sole responsibility that the	
<p><b>Sicherheitsfunktion STO</b> innerhalb der Servoregler <b>smartServo BL 4102-C</b> <b>smartServo BL 4104-C</b></p>	<p><b>Safety function STO</b> within the servo drives <b>smartServo BL 4102-C</b> <b>smartServo BL 4104-C</b></p>
konform ist mit den Vorschriften der folgenden Richtlinien und Normen:	
complies with the following directives and standards:	
<p><b>Maschinenrichtlinie</b> 2006/42/EG</p> <p>Angewandte harmonisierte Normen: <b>EN 61800-5-2:2017</b> max. SIL 3 (Sicherheitsfunktionen siehe Betriebsanleitung) <b>EN 62061:2005+AC:2010+A1:2013+A2:2015</b> max. SIL CL 3 (Sicherheitsfunktionen siehe Betriebsanleitung) <b>EN ISO 13849-1:2015</b> max. Kategorie 4 PL e (Sicherheitsfunktionen siehe Betriebsanleitung) <b>IEC 61508 Teil 1-7:2010</b> max. SIL 3 (Sicherheitsfunktionen siehe Betriebsanleitung)</p>	<p><b>Machinery Directive</b> 2006/42/EC</p> <p>Applied harmonized standards: <b>EN 61800-5-2:2017</b> max. SIL 3 (safety functions see manual) <b>EN 62061:2005+AC:2010+A1:2013+A2:2015</b> max. SIL CL 3 (safety functions see manual) <b>EN ISO 13849-1:2015</b> max. Category 4 PL e (safety functions see manual) <b>IEC 61508 Parts 1-7:2010</b> max. SIL 3 (safety functions see manual)</p>
<p><b>Konformitätsbewertung</b></p> <p>Das bezeichnete Produkt verfügt über die integrierte Sicherheitsfunktion STO. Es wird bestätigt, dass der Prüfgegenstand mit den Anforderungen nach Anhang I der Richtlinie 2006/42/EG über Maschinen übereinstimmt.</p> <p><b>Benannte Stelle</b> TÜV Rheinland Industrie Service GmbH Certification Body for Machinery, NB 0035 Alboinstrasse 56 12103 Berlin / Germany</p> <p>Zertifikat: 01/205/5701.00/19</p> <p>Gültigkeit 31.01.2024</p>	<p><b>Conformity Assessment</b></p> <p>The designated product offers the integrated safety function STO. It is confirmed, that the product under test complies with the requirements for machines defined in Annex I of the EC Directive 2006/42/EC.</p> <p><b>Notified body</b> TÜV Rheinland Industrie Service GmbH Certification Body for Machinery, NB 0035 Alboinstrasse 56 12103 Berlin / Germany</p> <p>Certificate: 01/205/5701.00/19</p> <p>Date of expiry 2024-01-31</p>
FM 7.3.3-5 Vers. 1.1	(1/2)



**Weitere angewandte nicht harmonisierte Normen oder sonstige Spezifikationen:**

keine

**Besondere Bedingungen:**

Diese Erklärung bescheinigt die Übereinstimmung mit den genannten Richtlinien, beinhaltet jedoch keine Zusicherung von Eigenschaften.

Die Sicherheits- und Installationshinweise der Produktdokumentation sind zu beachten.

Die Produkte sind bestimmt zum Einbau in Maschinen. Die Inbetriebnahme ist solange untersagt bis festgestellt wurde, dass die Maschine, in welche diese Produkte eingebaut werden sollen, den Bestimmungen der o.g. EG Richtlinie entsprechen.

**More applied non-harmonized standards or specifications:**

None

**Specific Requirements:**

This declaration certifies compliance with the stated Directive, but implies no warranty of properties.

The safety and installation instructions of the product documentation are to be considered

These products are intended for installation in machines. Operation is prohibited until it has been determined that the machines in which these products are to be installed, conforms to the above mentioned EC Directive.

Ort / Place Braunschweig

Datum / Date 21.02.2019

Director Sales & Commercial

General Manager

Unterschrift /  
Signature:

  
Volker Meier

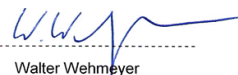
  
Walter Wehmeyer

## > BL 4300-C



# 06/2020

### EG Konformitätserklärung

### EC Declaration of Conformity

**Metronix Meßgeräte und Elektronik GmbH, Kocherstrasse 3, 38120 Braunschweig GERMANY**

erklärt hiermit in alleiniger Verantwortung, dass die

hereby declares under sole responsibility that the

**Sicherheitsfunktion STO**  
innerhalb der Servoregler  
smartServo BL 4304-C  
smartServo BL 4308-C  
smartServo BL 4312-C

**Safety function STO**  
within the servo drives  
smartServo BL 4304-C  
smartServo BL 4308-C  
smartServo BL 4312-C

konform ist mit den Vorschriften der folgenden Richtlinien und Normen:

complies with the following directives and standards:

#### Maschinenrichtlinie 2006/42/EG

Angewandte harmonisierte Normen:

**EN 61800-5-2:2017**  
max. SIL 3  
(Sicherheitsfunktionen siehe Betriebsanleitung)  
**EN 62061:2005+AC:2010+A1:2013+A2:2015**  
max. SIL CL 3  
(Sicherheitsfunktionen siehe Betriebsanleitung)  
**EN ISO 13849-1:2015**  
max. Kategorie 4  
PL e  
(Sicherheitsfunktionen siehe Betriebsanleitung)  
**IEC 61508 Teil 1-7:2010**  
max. SIL 3  
(Sicherheitsfunktionen siehe Betriebsanleitung)

#### Machinery Directive 2006/42/EC

Applied harmonized standards:

**EN 61800-5-2:2017**  
max. SIL 3  
(safety functions see manual)  
**EN 62061:2005+AC:2010+A1:2013+A2:2015**  
max. SIL CL 3  
(safety functions see manual)  
**EN ISO 13849-1:2015**  
max. Category 4  
PL e  
(safety functions see manual)  
**IEC 61508 Parts 1-7:2010**  
max. SIL 3  
(safety functions see manual)

#### Konformitätsbewertung

Das bezeichnete Produkt verfügt über die integrierte Sicherheitsfunktion STO. Es wird bestätigt, dass der Prüfgegenstand mit den Anforderungen nach Anhang I der Richtlinie 2006/42/EG über Maschinen übereinstimmt.

#### Benannte Stelle

TÜV Rheinland Industrie Service GmbH  
Certification Body for Machinery, NB 0035  
Alboinstrasse 56  
12103 Berlin / Germany

Zertifikat:

01/205/5701.00/19

Gültigkeit

31.01.2024

#### Conformity Assessment

The designated product offers the integrated safety function STO. It is confirmed, that the product under test complies with the requirements for machines defined in Annex I of the EC Directive 2006/42/EC.

#### Notified body

TÜV Rheinland Industrie Service GmbH  
Certification Body for Machinery, NB 0035  
Alboinstrasse 56  
12103 Berlin / Germany

Certificate:

01/205/5701.00/19

Date of expiry

2024-01-31



**Weitere angewandte nicht harmonisierte Normen oder sonstige Spezifikationen:**

keine

**More applied non-harmonized standards or specifications:**

None

**Besondere Bedingungen:**

Diese Erklärung bescheinigt die Übereinstimmung mit den genannten Richtlinien, beinhaltet jedoch keine Zusicherung von Eigenschaften.

Die Sicherheits- und Installationshinweise der Produktdokumentation sind zu beachten.

Die Produkte sind bestimmt zum Einbau in Maschinen. Die Inbetriebnahme ist solange untersagt bis festgestellt wurde, dass die Maschine, in welche diese Produkte eingebaut werden sollen, den Bestimmungen der o.g. EG Richtlinie entsprechen.

**Specific Requirements:**

This declaration certifies compliance with the stated Directive, but implies no warranty of properties.

The safety and installation instructions of the product documentation are to be considered

These products are intended for installation in machines. Operation is prohibited until it has been determined that the machines in which these products are to be installed, conforms to the above mentioned EC Directive.

Ort / Place ..... Braunschweig .....

Datum / Date ..... 25.06.2020 .....

Director Sales & Commercial

General Manager

Unterschrift /  
Signature:



Olaf Donner 25.06.2020



Walter Wehmeyer 29. JUNI 2020

## 9.3 cULus certification

### > BL 4100-C

#### CERTIFICATE OF COMPLIANCE

**Certificate Number** 20190131-E219816  
**Report Reference** E219816-20190123  
**Issue Date** 2019-JANUARY-31

**Issued to:** Metronix Messgeraete und Elektronik GmbH  
 Kocherstr. 3  
 38120 Braunschweig GERMANY

**This certificate confirms that  
 representative samples of**

POWER CONVERSION EQUIPMENT  
 Open type power conversion equipment,  
 Cat. No. BL 4102-C, BL 4104-C.

Have been investigated by UL in accordance with the  
 Standard(s) indicated on this Certificate.

**Standard(s) for Safety:** UL 61800-5-1 - Adjustable Speed Electrical Power Drive  
 Systems - Part 5-1: Safety Requirements - Electrical,  
 Thermal and Energy  
 CSA-C22.2 No. 274 - Adjustable Speed Drives

**Additional Information:** See the UL Online Certifications Directory at  
<https://iq.ulprospector.com> for additional information.

This *Certificate of Compliance* does not provide authorization to apply the UL Mark. Only the UL Follow-Up  
 Services Procedure provides authorization to apply the UL Mark.

Only those products bearing the UL Mark should be considered as being UL Certified and covered under UL's  
 Follow-Up Services.

Look for the UL Certification Mark on the product.



Bruce Mahrenholz, Director North American Certification Program  
 UL LLC

Any information and documentation involving UL Mark services are provided on behalf of UL LLC (UL) or any authorized licensee of UL. For questions, please  
 contact a local UL Customer Service Representative at <http://ul.com/about/locations/>



➤ **BL 4300-C**

## CERTIFICATE OF COMPLIANCE

**Certificate Number** E219816  
**Report Reference** E219816-20200423  
**Issue Date** 2020-APRIL-24

**Issued to:** Metronix Messgeraete und Elektronik GmbH  
 Kocherstr. 3  
 38120 Braunschweig GERMANY

**This certificate confirms that  
 representative samples of**

**POWER CONVERSION EQUIPMENT**  
 Open type power conversion equipment, Cat. No.  
 smartServo BL 4304-C, smartServo BL 4308-C, smartServo  
 BL 4312-C.

Have been investigated by UL in accordance with the  
 Standard(s) indicated on this Certificate.

**Standard(s) for Safety:** UL 61800-5-1 - STANDARD FOR ADJUSTABLE SPEED  
 ELECTRICAL POWER DRIVE SYSTEMS - PART 5-1:  
 SAFETY REQUIREMENTS - ELECTRICAL, THERMAL  
 AND ENERGY  
 CSA C22.2 NO. 274-17 - ADJUSTABLE SPEED DRIVES

**Additional Information:** See the UL Online Certifications Directory at  
<https://iq.ulprospector.com> for additional information.

This *Certificate of Compliance* does not provide authorization to apply the UL Mark. Only the UL Follow-Up  
 Services Procedure provides authorization to apply the UL Mark.

Only those products bearing the UL Mark should be considered as being UL Certified and covered under UL's  
 Follow-Up Services.

Look for the UL Certification Mark on the product.



Bruce Mahrenholz, Director North American Certification Program  
 UL LLC

Any information and documentation involving UL Mark services are provided on behalf of UL LLC (UL) or any authorized licensee of UL. For questions, please  
 contact a local UL Customer Service Representative at <http://ul.com/about/locations/>



## Original Mounting Instructions

### › Copyright

© 2023 Metronix Meßgeräte und Elektronik GmbH. All rights reserved.

The information and data in this document have been composed to the best of our knowledge. However, deviations between the document and the product cannot be excluded entirely. For the devices and the corresponding software in the version handed out to the customer, Metronix guarantees the contractual use in accordance with the user documentation. In the case of serious deviations from the user documentation, Metronix has the right and the obligation to repair, unless it would involve an unreasonable effort. A possible liability does not include deficiencies caused by deviations from the operating conditions intended for the device and described in the user documentation.

Metronix does not guarantee that the products meet the buyer's demands and purposes or that they work together with other products selected by the buyer. Metronix does not assume any liability for damage resulting from the combined use of its products with other products or resulting from improper handling of machines or systems.

Metronix reserves the right to modify, amend or improve the document or the product without prior notification.

This document may, neither entirely nor in part, be reproduced, translated into any other natural or machine-readable language nor transferred to electronic, mechanical, optical or any other kind of data media, without the express authorisation of the author.

### › Trademarks

Any product names in this document may be registered trademarks. The sole purpose of any trademarks in this document is the identification of the corresponding products.