



Operating & Installation Manual

TETRA & TETRA COMPACT

File name	Operating & Installation Manual Tetra & Tetra Compact
Version:	1.0 - 2014
Date	

Motor Power Company s.r.l.

Via Leonardo Da Vinci, 4
42024 Castelnovo Sotto Reggio Emilia - Italia
Tel. +39 0522 682710 - Fax +39 0522 683552
info@motorpowerco.it - motorpowerco.com
Cap. Soc. 250.000,00€ i.v. - R.E.A. di RE 175521
Iscr.Reg.Impr. di RE n.01308390358 - N. Mecc. RE 010210
C.F. e P.IVA IT 01308390358



Table of contents

1	Foreword	3
1.1	Notes on the documentation	3
1.2	Disclaimer	3
1.3	Copyright.....	3
1.4	Guarantee.....	4
1.5	Appropriate use	4
2	Guidelines and Standards	4
2.1	EC declaration of conformity	5
3	Safety	6
3.1	General safety instructions	6
3.1.1	Personnel qualification	6
3.1.2	Description of safety symbols	6
3.2	Special safety instructions for TETRA & TETRA COMPACT	7
4	Handling	8
4.1	Transport.....	8
4.2	Packaging.....	8
4.3	Storage	8
4.4	Maintenance / Cleaning.....	8
5	Technical description	9
5.1	Design of the motors.....	9
5.2	General technical data	9
5.3	Standard features	10
5.3.1	Style.....	10
5.3.2	Shaft end, A-side	10
5.3.3	Flange.....	10
5.3.4	Protection class	10
5.3.5	Insulation material class	10
5.3.6	Connection technology	11
5.3.7	Holding brake	11
5.4	Options	12
5.5	Selection criteria	12
6	Mechanical installation	13
6.1	Important notes	13
7	Electrical installation	14
7.1	Important notes	14
7.2	Connection of motors with pre-assembled cables	15
8	Commissioning	16
8.1	Important notes	16
8.2	Guide for commissioning	16
8.3	Troubleshooting	16
9	Appendix	18
9.1	Support and Service	18
9.1.1	Motor Power Company Support	18
9.1.2	Motor Power Company Service.....	18
9.2	Motor Power Company headquarters	18

Motor Power Company s.r.l.

Via Leonardo Da Vinci, 4
 42024 Castelnovo Sotto Reggio Emilia - Italia
 Tel. +39 0522 682710 - Fax +39 0522 683552
 info@motorpowerco.it - motorpowerco.com
 Cap. Soc. 250.000,00€ i.v. - R.E.A. di RE 175521
 Iscr.Reg.Impr. di RE n.01308390358 - N. Mecc. RE 010210
 C.F. e P.IVA IT 01308390358



1 Foreword

1.1 Notes on the documentation

This description is only intended for trained specialists in control, automation and drive engineering who are familiar with the applicable national standards. It is essential that the following notes and explanations are followed when installing and commissioning these components. The "General safety instructions" and "Special safety instructions for Tetra & Tetra Compact" sections are also essential.

The responsible staff must ensure that the application or use of the products described satisfy all the requirements for safety, including all the relevant laws, regulations, guidelines and standards.

 CAUTION	<p>Danger for persons, the environment or equipment</p> <p>Please observe the entire documentation which consists of:</p> <ul style="list-style-type: none"> - Tetra & Tetra Compact documentation (this manual) - Complete documentation (online and paper) for Motor Power Company servo drives available at www.motorpowerco.com - Complete machine documentation (provided by the machine manufacturer)
---	---

1.2 Disclaimer

This documentation has been prepared with care. The products described are, however, constantly under development.

For this reason, the documentation may not always have been fully checked for consistency with the performance data, standards or other characteristics described.

If it should contain technical or editorial errors, we reserve the right to make changes at any time and without notice.

No claims for the modification of products that have already been supplied may be made on the basis of the data, diagrams and descriptions in this documentation.

1.3 Copyright

Motor Power Company s.r.l. owns the copyright of this manual, which was designed for machine operators and maintenance personnel. The instructions and specifications it contains may be neither completely nor partially copied, distributed or examined by unauthorised persons for the benefit of our competitors, or disclosed to third parties. Motor Power Company s.r.l. reserves the right to take legal action against anyone breaching this condition.

Motor Power Company s.r.l.

Via Leonardo Da Vinci, 4
 42024 Castelnovo Sotto Reggio Emilia - Italia
 Tel. +39 0522 682710 - Fax +39 0522 683552
info@motorpowerco.it - motorpowerco.com
 Cap. Soc. 250.000,00€ i.v. - R.E.A. di RE 175521
 Iscr.Reg.Impr. di RE n.01308390358 - N. Mecc. RE 010210
 C.F. e P.IVA IT 01308390358



1.4 Guarantee

Motor Power Company s.r.l. guarantees its products for a period of 12 (twelve) months from the date of purchase. This guarantee consists exclusively of the repair or replacement without charge of any parts that our Service Department has examined and has deemed faulty.

Barring any liability for direct and/or indirect damages, this guarantee only covers material faults and will be null and void should parts have been removed, in case of tampering or repairs that were not undertaken at our premises and/or by unauthorised personnel.

All equipment returned must be sent carriage paid, even during the guarantee period.

1.5 Appropriate use

Synchronous servomotors of the Tetra & Tetra Compact series are designed as drives for handling equipment, textile machines, machine tools, packaging machines and similar machines with demanding requirements in terms of dynamics. The motors of the Tetra & Tetra Compact series are **mainly** intended for speed- and/or torque-controlled operation via digital Motor Power Company servo drive.

 <p>WARNING</p>	<p>Caution – Risk of injury! Electronic equipment is not fail-safe. The machine manufacturer is responsible for ensuring that the connected motors and the machine are brought into a safe state in the event of a fault in the drive system.</p>
---	--

The servomotors from the Tetra & Tetra Compact series are exclusively designed for installation as components in electrical systems or machines and may only be operated as integrated components of the system or machine. The motors may **only** be operated under the ambient conditions defined in this documentation.

2 Guidelines and Standards

 <p>CAUTION</p>	<p>Danger for persons, the environment or equipment Servomotors of the Tetra & Tetra Compact series are not classified as products within the meaning of the EC Machinery Directive. Operation of the servomotors in machines or systems is only permitted once the machine or system manufacturers has provided evidence of CE conformity of the complete machine or system.</p>
---	--

Motor Power Company s.r.l.

Via Leonardo Da Vinci, 4
42024 Castelnovo Sotto Reggio Emilia - Italia
Tel. +39 0522 682710 - Fax +39 0522 683552
info@motorpowerco.it - motorpowerco.com
Cap. Soc. 250.000,00€ i.v. - R.E.A. di RE 175521
Iscr.Reg.Impr. di RE n.01308390358 - N. Mecc. RE 010210
C.F. e P.IVA IT 01308390358

**MOTOR
POWER**
COMPANY

2.1 EC declaration of conformity

The Manufacturer:

Motor Power Company S.r.l.

Via L. Da Vinci, 4 - 42024 Castelnovo Sotto (RE) ITALY

Declares that the products:

Brushless rotative servomotors series:

TETRA - TETRA COMPACT

Are in conformity with the requirements of following European Directives:

- Directive 2006/95/CE: relating to electrical equipment designed for use within certain voltage limits
- Directive 2004/108/CE: relating to electromagnetic compatibility.

and their following modifications.

Have also been manufactured enforcing the following norms:

- EN 60034-1
- EN 60034-2
- EN 60034-5
- EN 60034-6
- EN 60034-7

Are suitable for being included in a machine that will be declared in compliance with the Machinery directive 2006/42/CE and following modifications.

Castelnovo Sotto, 29 december 2009

Motor Power Company S.r.l.

Stefano Grandi C E O

Motor Power Company s.r.l.

Via Leonardo Da Vinci, 4
42024 Castelnovo Sotto Reggio Emilia - Italia
Tel. +39 0522 682710 - Fax +39 0522 683552
info@motorpowerco.it - motorpowerco.com
Cap. Soc. 250.000,00€ i.v. - R.E.A. di RE 175521
Iscr.Reg.Impr. di RE n.01308390358 - N. Mecc. RE 010210
C.F. e P.IVA IT 01308390358

**MOTOR
POWER**
COMPANY

3 Safety







3.1 General safety instructions

3.1.1 Personnel qualification

This description is only intended for trained specialists in control, automation and drive engineering who are familiar with the applicable national standards.

3.1.2 Description of safety symbols

The following safety symbols and associated safety instructions are used in this document. These safety instructions must be read and followed.

 <p>DANGER</p>	<p>Serious risk of injury! Failure to follow the safety instructions associated with this symbol directly endangers the life and health of persons.</p>
 <p>WARNING</p>	<p>Caution – Risk of injury! Failure to follow the safety instructions associated with this symbol endangers the life and health of persons.</p>
 <p>CAUTION</p>	<p>Personal injuries! Failure to follow the safety instructions associated with this symbol can lead to injuries to persons.</p>
 <p>ATTENTION</p>	<p>Damage to the environment or devices! Failure to follow the safety instructions associated with this symbol can lead to damage to the environment or equipment.</p>
 <p>NOTE</p>	<p>Tip or pointer This symbol indicates information that contributes to better understanding.</p>
	<p>UL note This symbol indicates important information regarding UL certification.</p>

Motor Power Company s.r.l.

Via Leonardo Da Vinci, 4
42024 Castelnovo Sotto Reggio Emilia - Italia
Tel. +39 0522 682710 - Fax +39 0522 683552
info@motorpowerco.it - motorpowerco.com
Cap. Soc. 250.000,00€ i.v. - R.E.A. di RE 175521
Iscr.Reg.Impr. di RE n.01308390358 - N. Mecc. RE 010210
C.F. e P.IVA IT 01308390358





3.2 Special safety instructions for TETRA & TETRA COMPACT

The safety instructions are designed to avert danger and must be followed during installation, commissioning, production, troubleshooting, maintenance and trial or test assemblies.

The servomotors of the Tetra & Tetra Compact series are not designed for stand-alone operation and are always installed in a machine or system. After installation the additional documentation and safety instructions provided by the machine manufacturer must be read and followed.

 <p>WARNING</p>	<p>Serious risk of injury through high electrical voltage!</p> <ul style="list-style-type: none"> • Never open the servomotor when it is live. Opening the device would invalidate any warranty and liability claims against Motor Power Company s.r.l. • Negligent, improper handling of the servomotor and bypassing of the safety devices can lead to personal injury or death through electric shock. • Ensure that the protective conductor is connected properly. • The machine manufacturer must prepare a hazard analysis for the machine, and must take appropriate measures to ensure that unexpected movements can not lead to injury to persons or to material damage. • Power leads may be live, even if the motor is not running. Never undo the electrical connections to the motor when it is live. Under unfavourable conditions arcing may occur, resulting in injury and damage to contacts. • Disconnect the servomotor from the servo terminal and secure it against reconnection.
---	--

 <p>WARNING</p>	<p>Serious risk of injury through hot surfaces!</p> <ul style="list-style-type: none"> • The surface temperature may exceed 50 °C, resulting in a risk of burns. • Avoid touching the housing during or shortly after operation. • Leave the servomotor to cool down for at least 15 minutes after it is switched off and use a thermometer to check whether the surface has cooled down sufficiently.
--	--

 <p>ATTENTION</p>	<p>Danger for persons, the environment or equipment</p> <ul style="list-style-type: none"> • Carefully read this manual before using the servomotor thoroughly, paying particular attention to the safety instructions. In the event of any uncertainties please notify your sales office immediately and refrain from working on the servomotor. • Only well trained, qualified electricians with sound knowledge of drive equipment may work on the device. • During installation it is essential to ensure that the specified ventilation clearances and climatic conditions are adhered to. Further information can be found in the "Technical data" and "Mechanical installation" sections. • If a servomotor is installed in a machine it must not be commissioned until proof of compliance of the machine with the latest version of the EC Machinery Directive has been provided. This includes all relevant armonised standards and regulations required for implementation of this Directive in national legislation.
---	---

Motor Power Company s.r.l.

Via Leonardo Da Vinci, 4
 42024 Castelnovo Sotto Reggio Emilia - Italia
 Tel. +39 0522 682710 - Fax +39 0522 683552
 info@motorpowerco.it - motorpowerco.com
 Cap. Soc. 250.000,00€ i.v. - R.E.A. di RE 175521
 Iscr.Reg.Impr. di RE n.01308390358 - N. Mecc. RE 010210
 C.F. e P.IVA IT 01308390358



4 Handling

4.1 Transport

- Transport humidity: relative humidity 5% - 95%, non-condensing
- The servomotor may only be transported by qualified personnel and in the manufacturer's original recyclable packaging.
- Avoid hard impacts, particularly at the shaft end.
- If the packaging is damaged, check the motor for visible damage. Inform the transport company and, if necessary, the manufacturer.

4.2 Packaging

Cardboard packaging with Instapak® foam cushion.

Motor Type	Carton	Max. stacking height
Tetra & Tetra Compact	X	10

4.3 Storage

- Air humidity: relative humidity 5% - 95%, non-condensing
- Max. stacking height: see table Packaging
- Storage time: without limitation
- Store only in the manufacturer's original recyclable packaging

4.4 Maintenance / Cleaning

- Maintenance and cleaning only by qualified personnel.
- The ball bearings have a grease filling with a service life of 20,000 hours under normal operating conditions. The bearings should be replaced after 20,000 hours of operation under rated conditions.
- Check the motor for bearing noise every 2,500 operating hours or once per year. If any noises are heard, stop the operation of the motor. The bearings must be replaced.
- Opening the motor invalidates the warranty.
- Clean the housing with isopropanol or similar.

 <p>ATTENTION</p>	<p>Destruction of the servomotor</p> <p>Never immerse or spray the servomotor.</p>
---	---

Motor Power Company s.r.l.

Via Leonardo Da Vinci, 4
 42024 Castelnovo Sotto Reggio Emilia - Italia
 Tel. +39 0522 682710 - Fax +39 0522 683552
 info@motorpowerco.it - motorpowerco.com
 Cap. Soc. 250.000,00€ i.v. - R.E.A. di RE 175521
 Iscr.Reg.Impr. di RE n.01308390358 - N. Mecc. RE 010210
 C.F. e P.IVA IT 01308390358

**MOTOR
POWER**
COMPANY

5 Technical description

5.1 Design of the motors

The synchronous servomotors of the Tetra & Tetra Compact series are brushless three-phase motors for demanding servoapplications. In conjunction with our digital servo terminal they are particularly suitable for positioning tasks in industrial robots, machine tools, actuators etc. with demanding requirements in terms of dynamics and stability.

The servomotors are equipped with permanent magnets in the rotor. This advanced neodymium magnetic material makes a significant contribution to the motors' exceptional dynamic properties. A three-phase winding is housed in the stator, and this is powered by the servo drive. The motor has no brushes, the commutation being implemented electronically in the servo drive.

The motors normally have an integrated encoder to provide feedback. Motor Power Company servo drives analyse the encoder position and supply the motors with sine currents.

The motors are available with or without built-in holding brake which is free from backlash. The brake cannot be retrofitted.

The motors have a matt black coating (similar to RAL 9005). The finish is not resistant against solvents (e.g. trichlorethylene, thinners or similar).

5.2 General technical data

Ambient temperature (at rated values)	0 - +40 °C for site altitudes up to 1000 m amsl It is vital to consult our applications department for ambient temperatures above 40 °C and encapsulated installation of the motors.
Permissible humidity (at rated values)	95% relative humidity, non-condensing
Power derating (currents and torques)	For site altitudes above 1000 m amsl and 40 °C 6% at 2000 m amsl 17% at 3000m amsl 30% at 4000m amsl 55% at 5000m amsl No derating for site altitudes above 1000 m amsl with temperature reduction of 10K / 1000m
Ball bearing service life	=20,000 operating hours
Technical data	See product catalogue

Motor Power Company s.r.l.

Via Leonardo Da Vinci, 4
42024 Castelnovo Sotto Reggio Emilia - Italia
Tel. +39 0522 682710 - Fax +39 0522 683552
info@motorpowerco.it - motorpowerco.com
Cap. Soc. 250.000,00€ i.v. - R.E.A. di RE 175521
Iscr.Reg.Impr. di RE n.01308390358 - N. Mecc. RE 010210
C.F. e P.IVA IT 01308390358



5.3 Standard features

5.3.1 Style

The basic style for the Tetra & Tetra Compact synchronous servomotors is IM B5 according to DIN EN 60034-7.

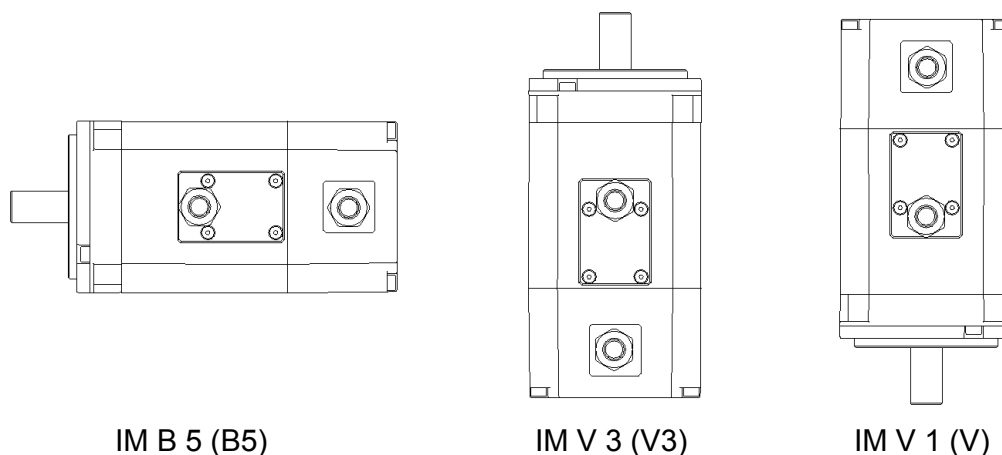

IM B 5 (B5)

IM V 3 (V3)

IM V 1 (V)

5.3.2 Shaft end, A-side

Power transmission is made through the cylindrical shaft end A, fit **h7** according to EN 50347. The bearings are designed for a service life of 20,000 hours.

Radial force

If the motors drive via pinions or toothed belts, then high radial forces will occur. The permissible values at the shaft end, depending on the speed.

Axial force

Axial forces arise when assembling pinions or pulleys on the shaft and using angular gearheads, for example. The permissible maximum values can be found in the technical data.

Coupling

Double-coned collets, possibly in association with metal bellows couplings, have proven themselves as excellent, zero backlash coupling elements.

5.3.3 Flange

Flange dimensions according to IEC standard, fit **h7** accuracy according to DIN 42955

Tolerance class: **N**

5.3.4 Protection class

Standard version (body), except "V3" IP65

Standard shaft bushing IP40

5.3.5 Insulation material class

The motors conform to insulation material class F according to IEC 60085.

Motor Power Company s.r.l.

Via Leonardo Da Vinci, 4
42024 Castelnovo Sotto Reggio Emilia - Italia
Tel. +39 0522 682710 - Fax +39 0522 683552
info@motorpowerco.it - motorpowerco.com
Cap. Soc. 250.000,00€ i.v. - R.E.A. di RE 175521
Iscr.Reg.Impr. di RE n.01308390358 - N. Mecc. RE 010210
C.F. e P.IVA IT 01308390358

**MOTOR
POWER**
COMPANY

5.3.6 Connection technology

The motors are fitted with connectors at the cable ends or on motor body, for the power supply and the feedback signals.

The mating connectors are not included in the scope of supply. We can supply preassembled feedback and power cables. Information regarding the cable materials can be found in product catalogue.

 <p>NOTE</p>	<p>Motor length The motor length depends on the built-in feedback unit, among other factors. Retrofitting is not possible.</p>
--	---

5.3.7 Holding brake

 <p>WARNING</p>	<p>Serious risk of injury! The holding brake is not personal safety. If the brake is released then the rotor can be moved without a remanent torque!</p>
---	---

The Tetra & Tetra Compact motors are optionally available with an in-built holding brake. When the brake is de-energised it blocks the rotor. **The holding brakes are designed as standstill brakes** and are not suited for repeated operational braking.

The holding brakes can be controlled directly by the servo drive (no personal safety!).

 <p>NOTE</p>	<p>Motor length The motor length depends on the built-in holding brake, among other factors. It is not possible to fit one at a later date.</p>
--	--

Motor Power Company s.r.l.

Via Leonardo Da Vinci, 4
42024 Castelnovo Sotto Reggio Emilia - Italia
Tel. +39 0522 682710 - Fax +39 0522 683552
info@motorpowerco.it - motorpowerco.com
Cap. Soc. 250.000,00€ i.v. - R.E.A. di RE 175521
Iscr.Reg.Impr. di RE n.01308390358 - N. Mecc. RE 010210
C.F. e P.IVA IT 01308390358

**MOTOR
POWER**
COMPANY

5.4 Options

Holding brake

The holding brake is integrated in the motor. It increases the motor length.

5.5 Selection criteria

The three-phase servomotors are designed for operation with servo drive. Both units together form a speed or torque control loop.

The main selection criteria are:

- Standstill torque	[Nm]
- Rated speed at rated supply voltage	[Rmp]
- Moment of inertia of motor and load	[kgcm ²]
- Effective torque (calculated)	[Nm]

The static load **and** the dynamic load (acceleration/braking) must be taken into account in the calculation of the required motors and servo drives. Formulas and calculation example are available from our applications department on request.

Motor Power Company s.r.l.

Via Leonardo Da Vinci, 4
42024 Castelnovo Sotto Reggio Emilia - Italia
Tel. +39 0522 682710 - Fax +39 0522 683552
info@motorpowerco.it - motorpowerco.com
Cap. Soc. 250.000,00€ i.v. - R.E.A. di RE 175521
Iscr.Reg.Impr. di RE n.01308390358 - N. Mecc. RE 010210
C.F. e P.IVA IT 01308390358



6 Mechanical installation

6.1 Important notes



ATTENTION

Destruction of the motors

- Protect the motors from unacceptable stresses. Take care, especially during transport and handling, that components are not bent and that insulation clearances are not altered.
- The site must be free of conductive and aggressive material. For V3-mounting (shaft end upwards), make sure that no liquids can enter the bearings. If an encapsulated assembly is required, please consult our applications department beforehand.
- Ensure unhindered ventilation of the motors and observe the permissible ambient and flange temperatures. For ambient temperatures above 40 °C please consult our applications department beforehand.
- Servomotors are precision devices. The flange and shaft are especially vulnerable during storage and assembly. It is important to use the locking thread which is provided to tighten up couplings, gear wheels or pulleys and warm up the drive components, where possible. Blows or the use of force will lead to damage to the ball bearings and the shaft.

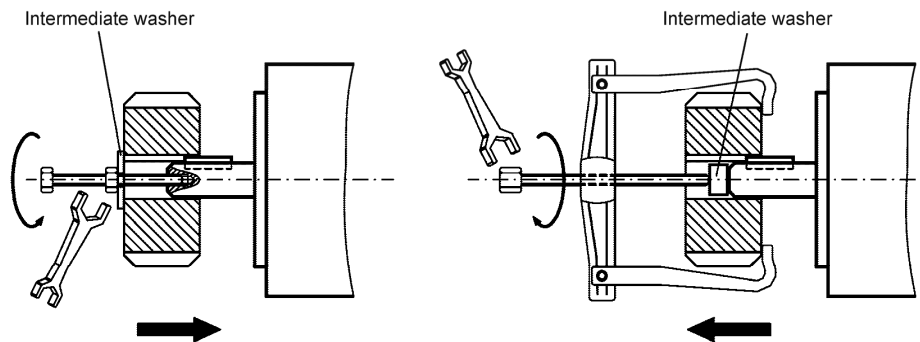

- Wherever possible, use only backlash-free, frictionally-locking collets or couplings. Ensure correct alignment of the couplings. A displacement will cause unacceptable vibration and the destruction of the ball bearings and the coupling.
- For toothed belts, it is vital to observe the permissible radial forces. An excessive radial load on the shaft will significantly shorten the life of the motor.
- Avoid axial loads on the motor shaft, as far as possible. Axial loading significantly shortens the life of the motor.
- In any case, avoid creating a mechanically constrained motor shaft mounting by using a rigid coupling with additional external bearings (e.g. in a gearbox).
- Take note of the no. of motor poles and the no. of resolver poles and ensure that the correct setting is made in the used servo drives. An incorrect setting can lead to the destruction of the motor, especially with small motors.
- Check compliance the permitted radial and axial loads F_R and F_A . When using a toothed belt drive, the **minimum** permitted diameter of the pinion follows from the equation:
$$d_{\min} \geq \frac{M_0}{F_R} \times 2$$



Motor Power Company s.r.l.

Via Leonardo Da Vinci, 4
42024 Castelnovo Sotto Reggio Emilia - Italia
Tel. +39 0522 682710 - Fax +39 0522 683552
info@motorpowerco.it - motorpowerco.com
Cap. Soc. 250.000,00€ i.v. - R.E.A. di RE 175521
Iscr.Reg.Impr. di RE n.01308390358 - N. Mecc. RE 010210
C.F. e P.IVA IT 01308390358



7 Electrical installation

7.1 Important notes

 <p>WARNING</p>	<p>Serious risk of injury through electric shock!</p> <ul style="list-style-type: none"> • Only staff qualified and trained in electrical engineering are allowed to wire up the motor. • Check the assignment of the servo drive and the motor. Compare the rated voltage and the rated current of the devices. • Always make sure that the motors are de-energised during assembly and wiring, i.e. no voltage may be switched on for any piece of equipment which is to be connected. Ensure that the control cabinet remains turned off (barrier, warning signs etc.). The individual voltages will only be turned on again during commissioning. • Never undo the electrical connections to the motor when it is live. Control and power leads may be live, even if the motor is not running.
 <p>ATTENTION</p>	<p>Smooth operation</p> <ul style="list-style-type: none"> • Ensure that there the servo terminal and the motor are earthed properly. See below for further information regarding EMC shielding and earthing. Earth the mounting plate and motor housing. • Route the power and control cables as separately as possible from one another. This will improve the immunity of the system to electromagnetic interference. If a motor power cable is used which includes integral brake control leads, then these brake control leads must be shielded. The shielding must be connected at both ends (see below).

Motor Power Company s.r.l.

Via Leonardo Da Vinci, 4
 42024 Castelnovo Sotto Reggio Emilia - Italia
 Tel. +39 0522 682710 - Fax +39 0522 683552
 info@motorpowerco.it - motorpowerco.com
 Cap. Soc. 250.000,00€ i.v. - R.E.A. di RE 175521
 Iscr.Reg.Impr. di RE n.01308390358 - N. Mecc. RE 010210
 C.F. e P.IVA IT 01308390358

**MOTOR
 POWER**
 COMPANY

7.2 Connection of motors with pre-assembled cables

Motor Power Company offers preassembled motor and feedback cables for safe, faster and flawless installation of the motors. Motor Power Company cables have been tested with regard to the materials, shielding and connectors used. They ensure proper functioning and compliance with statutory regulations such as EMC, UL etc. The use of other cables may lead to unexpected interference and invalidate the warranty.

- Carry out the wiring in accordance with the valid standards and regulations.
- Only use our preassembled shielded cables for the power and feedback connections.
- Connect up the shielding according to the wiring diagrams. Incorrectly installed shielding inevitably leads to EMC interference.

All available cable types are listed in product catalogue. Should you require additional information please contact our support.

Motor Power Company s.r.l.

Via Leonardo Da Vinci, 4
42024 Castelnovo Sotto Reggio Emilia - Italia
Tel. +39 0522 682710 - Fax +39 0522 683552
info@motorpowerco.it - motorpowerco.com
Cap. Soc. 250.000,00€ i.v. - R.E.A. di RE 175521
Iscr.Reg.Impr. di RE n.01308390358 - N. Mecc. RE 010210
C.F. e P.IVA IT 01308390358



8 Commissioning

8.1 Important notes

 <p>WARNING</p>	<p>Serious risk of injury!</p> <ul style="list-style-type: none"> • Only specialist personnel with extensive knowledge in the areas of electrical engineering/drive technology are allowed to install and commission the equipment. • The surface temperature of the motor can exceed 100 °C in operation. Check (measure) the temperature of the motor. Wait until the motor has cooled down below 40 °C before touching it. • Make sure that, even if the drive starts to move unintentionally, no danger can result for personnel or machinery.
---	--

8.2 Guide for commissioning

The procedure for commissioning is described as an example.

A different method may be appropriate or necessary, depending on the application of the equipment.

- Check the assembly and orientation of the motor.
- Check the drive components (coupling, gear unit, pulley) for the correct seating and setting (observe the permissible radial and axial forces).
- Check the wiring and connections to the motor and the servo drive. Check that the earthing is correct.
- Test the function of the holding brake, if used. (apply 24 V, the brake must be released).
- Check whether the rotor of the motor revolves freely (release the brake, if necessary). Listen out for grinding noises.
- Check that all the required measures against accidental contact with live and moving parts have been carried out.
- Carry out any further tests which are specifically required for your system.
- Now commission the drive according to the commissioning instructions for the servo drive.

8.3 Troubleshooting

The following table is to be seen as a “First Aid” box. There can be a large number of different reasons for a fault, depending on the particular conditions in your system. The fault causes described below are mostly those which directly influence the motor. Peculiarities which show up in the control behaviour can usually be traced back to an error in the parameterisation of the servo drive.

Our applications department can give you further help with your problems.

Motor Power Company s.r.l.

Via Leonardo Da Vinci, 4
 42024 Castelnovo Sotto Reggio Emilia - Italia
 Tel. +39 0522 682710 - Fax +39 0522 683552
 info@motorpowerco.it - motorpowerco.com
 Cap. Soc. 250.000,00€ i.v. - R.E.A. di RE 175521
 Iscr.Reg.Impr. di RE n.01308390358 - N. Mecc. RE 010210
 C.F. e P.IVA IT 01308390358



Fault	Possible cause	Measures to remove the cause
Motor doesn't rotate	<ul style="list-style-type: none"> • Servo drive not enabled • Break in setpoint lead • Motor phases in wrong sequence • Brake not released • Drive is mechanically blocked 	<ul style="list-style-type: none"> • Supply ENABLE signal • Check setpoint lead • Correct the phase sequence • Check brake control • Check mechanism
Motor runs away	<ul style="list-style-type: none"> • Motor phases in wrong sequence 	<ul style="list-style-type: none"> • Correct the phase sequence
Motor oscillates	<ul style="list-style-type: none"> • Break in the shielding of the feedback cable • Amplification to high 	<ul style="list-style-type: none"> • Replace feedback cable • Use motor default values
Drive error message: output stage fault	<ul style="list-style-type: none"> • Motor cable has short circuit or earth leakage • Motor has short circuit or earth leakage 	<ul style="list-style-type: none"> • Replace motor cable • Replace motor
Drive error message: feedback	<ul style="list-style-type: none"> • Connector is not properly plugged in • Break in cable, cable crushed or similar 	<ul style="list-style-type: none"> • Check connector • Check cables
Brake does not grip	<ul style="list-style-type: none"> • Required holding torque too high • Brake faulty 	<ul style="list-style-type: none"> • Check the dimensioning • Replace motor

Motor Power Company s.r.l.

Via Leonardo Da Vinci, 4
42024 Castelnuovo Sotto Reggio Emilia - Italia
Tel. +39 0522 682710 - Fax +39 0522 683552
info@motorpowerco.it - motorpowerco.com
Cap. Soc. 250.000,00€ i.v. - R.E.A. di RE 175521
Iscr.Reg.Impr. di RE n.01308390358 - N. Mecc. RE 010210
C.F. e P.IVA IT 01308390358



9 Appendix

9.1 Support and Service

Motor Power Company around the world offers comprehensive support and service, making available fast and competent assistance with all questions related to Motor Power Company products and system solutions.

9.1.1 Motor Power Company Support

Motor Power Company offers comprehensive technical support that deals not only with the application of individual Motor Power Company products, but offers extensive additional services:

- support
- design, programming and commissioning of complex automation systems
- extensive training program for Motor Power Company system components

Phone : +39 0522 682710

Fax : +39 0522 683552

e-mail : info@motorpowerco.it

9.1.2 Motor Power Company Service

The Motor Power Company Service Center supports you in all matters of after-sales service:

- local service
- repair service
- spare parts service

Phone : +39 0522 682710

Fax : +39 0522 683552

e-mail : info@motorpowerco.it

9.2 Motor Power Company headquarters

Motor Power Company S.r.l.
Via Leonardo Da Vinci, 4
42024 Castelnovo di Sotto (Reggio Emilia)
Italy

Phone : +39 0522 682710

Fax : +39 0522 683552

e-mail : info@motorpowerco.it

The addresses of the worldwide Motor Power Company branch offices and representatives can be found on our website at www.motorpowerco.com

You will also find further documentation Motor Power Company components there.

Motor Power Company s.r.l.

Via Leonardo Da Vinci, 4
42024 Castelnovo Sotto Reggio Emilia - Italia
Tel. +39 0522 682710 - Fax +39 0522 683552
info@motorpowerco.it - motorpowerco.com
Cap. Soc. 250.000,00€ i.v. - R.E.A. di RE 175521
Iscr.Reg.Impr. di RE n.01308390358 - N. Mecc. RE 010210
C.F. e P.IVA IT 01308390358

