

TC4

# TETRA COMPACT 4

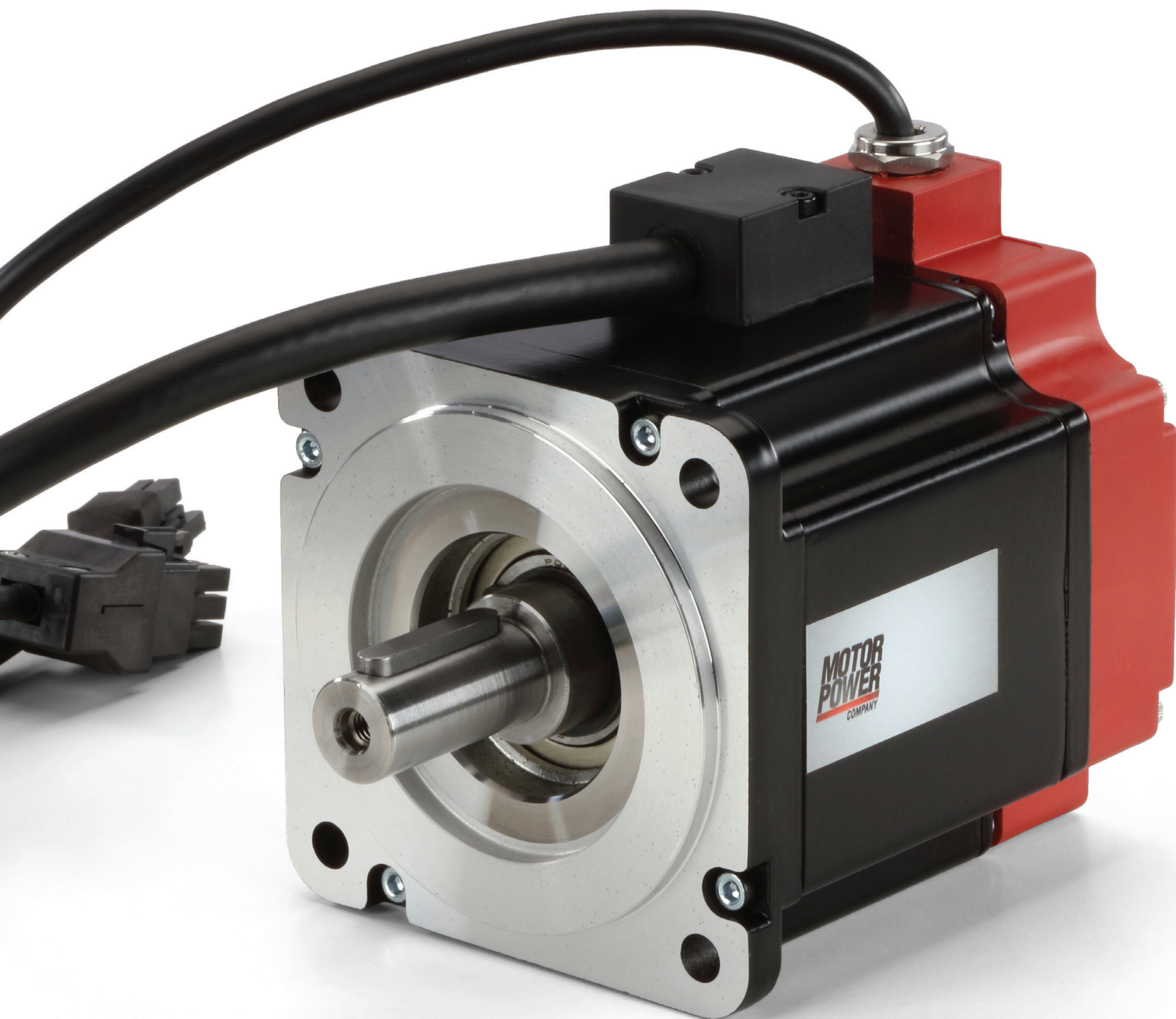

SEE IT BEFORE IT HAPPENS

**MOTOR  
POWER**  
COMPANY



TETRA COMPACT 4

# NEXT-LEVEL SERVO MOTORS

Introducing the TETRA COMPACT 4 series from Motor Power Company a breakthrough in high-performance brushless servo motors. Born from years of hands-on experience, these motors redefine the standards in the brushless servomotors category.

With a unique design that is 30% shorter than its predecessors, the TETRA COMPACT 4 series maintains exceptional power density, efficiency, and speed, setting a new benchmark for AC synchronous motors.

This series features 10-pole servomotors with a variety of feedback options, offering unmatched quality and a broad range of power ratings. Perfectly suited for modern machine performance requirements, Motor Power Company doesn't just provide individual components but complete motion solutions. Pairing these high-performance servomotors with versatile drives of the series BL servo, the TETRA COMPACT 4 series excels across a diverse array of applications. Welcome to a new era of innovation and efficiency in motion technology.

# CONTENTS

	Features	5
	Servomotor type designation	6
	Winding table code	7
	Product lineup	8
<b>TC4 40 1A</b>	Ratings and Specifications - Torque /Speed charts	10
<b>TC4 40 1B</b>	Ratings and Specifications - Torque /Speed charts	12
	External dimensions	14
<b>TC4 60 2A</b>	Ratings and Specifications - Torque /Speed charts	16
<b>TC4 60 2B</b>	Ratings and Specifications - Torque /Speed charts	18
	External dimensions	20
<b>TC4 80 3A</b>	Ratings and Specifications - Torque /Speed charts	22
<b>TC4 80 3B</b>	Ratings and Specifications - Torque /Speed charts	24
<b>TC4 80 3C</b>	Ratings and Specifications - Torque /Speed charts	26
	External dimensions	28
<b>TC4 100 4A</b>	Ratings and Specifications - Torque /Speed charts	30
<b>TC4 100 4B</b>	Ratings and Specifications - Torque /Speed charts	32
	External dimensions	34
<b>TC4 130 5F</b>	Ratings and Specifications - Torque /Speed charts	36
<b>TC4 130 5G</b>	Ratings and Specifications - Torque /Speed charts	37
<b>TC4 130 5H</b>	Ratings and Specifications - Torque /Speed charts	38
	External dimensions	39
<b>TC4 150 6A</b>	Ratings and Specifications - Torque /Speed charts	42
<b>TC4 150 6B</b>	Ratings and Specifications - Torque /Speed charts	43
<b>TC4 150 6C</b>	Ratings and Specifications - Torque /Speed charts	44
	External dimensions	45
<b>TC4 180 7A</b>	Ratings and Specifications - Torque /Speed charts	48
<b>TC4 180 7C</b>	Ratings and Specifications - Torque /Speed charts	49
<b>TC4 180 7D</b>	Ratings and Specifications - Torque /Speed charts	50
<b>TC4 180 7E</b>	Ratings and Specifications - Torque /Speed charts	51
<b>TC4 180 7F</b>	Ratings and Specifications - Torque /Speed charts	52
	External dimensions	53
	Feedback Resolver	55
	Feedback Encoder	56
	Brake features	59
	Wiring motor connection	60



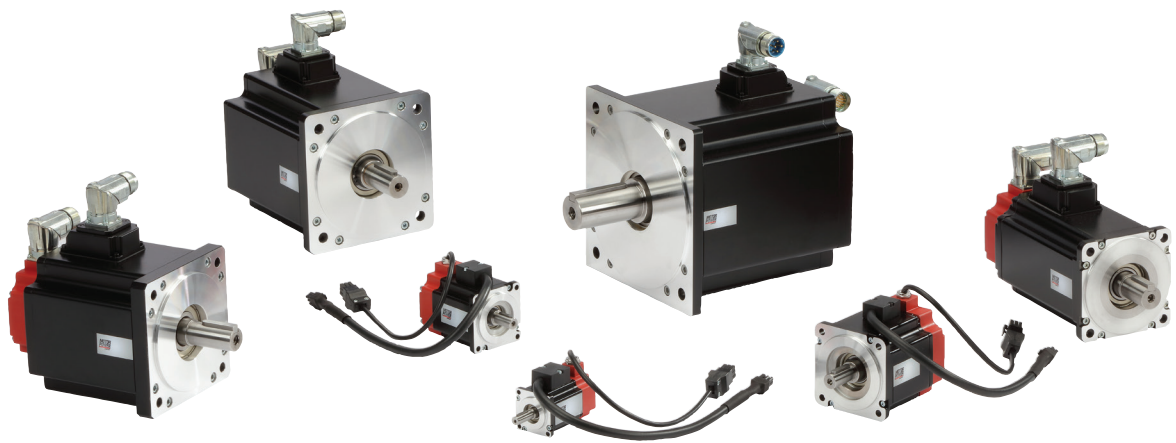

## FEATURES

<b>Motor type</b>	Three-phase BPM synchronous servo motor
<b>Available frame sizes</b>	40 - 60 - 80 - 100 - 130 - 150 - 180 mm
<b>Rated output torque</b>	From 0.16 to 47.75 Nm
<b>Rated output power</b>	From 50 to 7500 W
<b>Rated servomotor speed</b>	Up to 6000 rpm
<b>Maximum servomotor speed</b>	Up to 8000 rpm
<b>Insulation class</b>	F (155 °C)
<b>Protection class</b>	IP 65 (with oil seal)
<b>Ambient operating temperature</b>	-20 ÷ +40 °C
<b>Ambient storage temperature</b>	-40 ÷ +70 °C
<b>Relative humidity</b>	5 ÷ 85 %, non-condensing
<b>Cooling type</b>	Natural convective
<b>Maximum operating altitude</b>	Up to 3000 m above sea level (derating 1%/100m from 1000 onwards)
<b>Temperature sensor</b>	PT1000 (no sensor for size 40)
<b>Shaft end</b>	Smooth or keyed
<b>Feedback</b>	Resolver, TTL Encoder, Absolute Encoder (Hiperface, EnDat, BiSS Line, RS-485)*
<b>Bearing life</b>	20.000 h under rated operation condition
<b>Balancing quality grade</b>	G 6.3 according to ISO 1940
<b>Magnet material</b>	NdFeB with epoxy coating
<b>External coating</b>	RAL 9005 black powder
<b>Approvals</b>	CE, Rohs, Reach, UL file: E216686 - MPC IF 155

\*Available also in single cable configuration

# TC4 SERVOMOTOR TYPE DESIGNATION

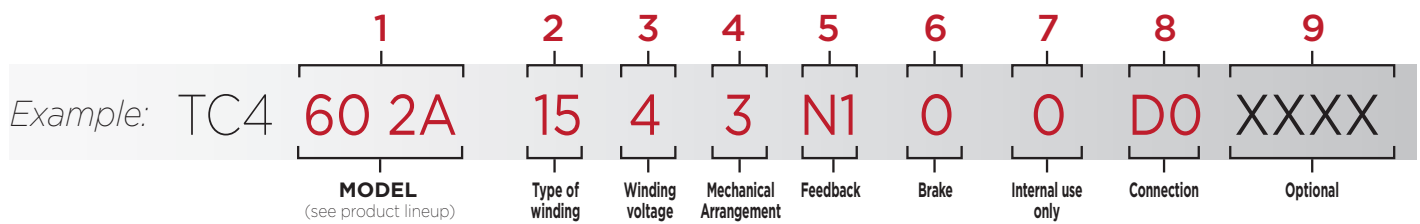

1	<b>MODEL</b>	See PRODUCT LINEUP (p.8)
2	<b>TYPE OF WINDING</b>	See WINDING TABLE CODE (p.7)
3	<b>WINDING VOLTAGE</b>	<ul style="list-style-type: none"> <li><b>0</b> → 24 Vdc</li> <li><b>1</b> → 48 Vdc</li> <li><b>6</b> → 60 Vdc</li> <li><b>2</b> → 230 Vac</li> <li><b>4</b> → 400 Vac</li> </ul>
4	<b>MECHANICAL ARRANGEMENT</b>	<ul style="list-style-type: none"> <li><b>0</b> Smooth shaft</li> <li><b>1</b> Smooth shaft + oil seal</li> <li><b>2</b> Keyed shaft</li> <li><b>3</b> Keyed shaft + oil seal</li> </ul>
5	<b>FEEDBACK</b>	<ul style="list-style-type: none"> <li><b>A1*</b> Hiperface absolute multi-turn encoder</li> <li><b>A3*</b> Hiperface DSL absolute single-turn 20 bit encoder</li> <li><b>A4*</b> Hiperface DSL absolute multi-turn 20 bit encoder</li> <li><b>A5*</b> Hiperface safety DSL single-turn 20 bit encoder</li> <li><b>A6*</b> Hiperface safety DSL multi-turn 20 bit encoder</li> <li><b>A15*</b> Hiperface safety DSL single-turn 24 bit encoder</li> <li><b>A16*</b> Hiperface safety DSL multi-turn 24 bit encoder</li> <li><b>A22*</b> Safety EnDat 3 single-turn 19 bit encoder</li> <li><b>A23*</b> Safety EnDat 3 multi-turn 19 bit encoder</li> <li><b>M1</b> TTL 2000 ppr encoder</li> <li><b>M2</b> Absolute single-turn 23 bit RS-485 encoder</li> <li><b>M3</b> Absolute single-turn 23 bit BiSS Line encoder</li> <li><b>N1</b> A-format 24-bit absolute multi-turn with external battery (not included). Encoder N1 available for models 40-60-80</li> <li><b>R1*</b> Resolver</li> </ul>

\*Not available for TC4 40 models

6	<b>BRAKE</b>	<ul style="list-style-type: none"> <li><b>0</b> Without brake</li> <li><b>1</b> With brake</li> </ul>
7	<b>INTERNAL USE ONLY</b>	<ul style="list-style-type: none"> <li><b>0</b> Without PWB</li> <li><b>1</b> With PWB</li> </ul>
8	<b>CONNECTION</b>	<ul style="list-style-type: none"> <li><b>D0</b> 300mm cable length with AMP connectors, (for 40-60-80 only)</li> <li><b>G2</b> 90° M23 turnable connectors - PT 1000 on power connector</li> <li><b>H2</b> 90° M23 turnable connectors - PT 1000 on signal connector</li> </ul>



## WINDING TABLE CODE

		TYPE OF WINDING																										
		9	13	15	15A	16	20	21	22	26	33	41	69	70	77	78	D1	D5	D6	F1	F2	G1	G5	H1	H3	L1	17	
SERVOMOTOR TYPE	TC4 40 1A	2									1	0			0	1												
	TC4 40 1B		2								1	0			0	1												
	TC4 60 2A			4		4	2	2																				
	TC4 60 2B			4		4	2	2																				
	TC4 80 3A			4		4	2	2																				
	TC4 80 3B			4		4	2	2																				
	TC4 80 3C			4		4	2	2																				
	TC4 100 4A			2													2		4									4
	TC4 100 4B			2														2								4		4
	TC4 130 5F																				2/4							
	TC4 130 5G																								2/4			
	TC4 130 5H								2/4																			
	TC4 150 6A			2			2							4														4
	TC4 150 6B			2																	2		4					4
	TC4 150 6C			2																	2		4					4
	TC4 180 7A									2/4																		
	TC4 180 7C				2/4																							
	TC4 180 7D																								2/4			
TC4 180 7E																								2/4				
TC4 180 7F													2/4															

## PRODUCT LINEUP

Servomotor Type	Nominal Power $P_n$ <small>(ref. to 3000 rpm)</small>	Nominal Power $P_n$ <small>(ref. to 6000 rpm)</small>	Nominal Torque $M_n$ <small>(ref. to 3000 rpm)</small>	Peak Torque $M_{max}$	Continuous Working Speed $n_M$	Maximum Working Speed $n_{Max}$	Moment of Inertia	24 Vdc	48 Vdc	230 Vac	400 Vac
	[W]	[W]	[Nm]	[Nm]	[rpm]	[rpm]	[kg cm <sup>2</sup> ]				
TC4 40 1A	50	85	0.16	0.56	3000/6000	8000	0.0305	√	√	√	√
TC4 40 1B	100	175	0.32	1.12	3000/6000	8000	0.0561	√	√	√	√
TC4 60 2A	200	350	0.64	2.24	3000/6000	8000	0.223			√	√
TC4 60 2B	400	600	1.27	4.44	3000/6000	8000	0.414			√	√
TC4 80 3A	400	700	1.27	4.44	3000/6000	8000	0.79			√	√
TC4 80 3B	750	1100	2.38	8.33	3000/6000	8000	1.42			√	√
TC4 80 3C	1000	1300	3.18	11.10	3000/6000	8000	2.03			√	√
TC4 100 4A	1000	-	3.18	16.50	3000	6000	2.53			√	√
TC4 100 4B	2000	-	6.37	33.00	3000	6000	4.61			√	√
TC4 130 5F	1000	-	3.18	14.30	3000	4000	6.70			√	√
TC4 130 5G	1500	-	4.77	21.48	3000	4000	9.72			√	√
TC4 130 5H	2000	-	6.36	28.65	3000	4000	12.77			√	√
TC4 150 6A	2500	-	7.95	33.42	3000	4000	15.18			√	√
TC4 150 6B	4000	-	12.73	66.85	3000	4000	27.68			√	√
TC4 150 6C	6000	-	19.10	100.27	3000	4000	40.17			√	√
TC4 180 7A	2000	-	6.37	28.65	3000	4000	25.22			√	√
TC4 180 7C	3500	-	11.14	50.30	3000	4000	-			√	√
TC4 180 7D	4500	-	28.65	71.62	1500	4000	-			√	√
TC4 180 7E	5500	-	35.00	87.53	1500	4000	-			√	√
TC4 180 7F	7500	-	47.75	119.37	1500	4000	-			√	√



MW  
P

TETRA  
COMPACT



40

			24 Vdc		48 Vdc		230 Vac	
TYPE OF WINDING			77	41	78	33	09	09
<b>ELECTRICAL DATA</b>								
Continuous stall torque (*)	$M_o$	[Nm]	0.18					
Peak torque	$M_{Max}$	[Nm]	0.56					
Nominal torque	$M_n$	[Nm]	0.16	0.135	0.16	0.135	0.16	0.135
Nominal power	$P_n$	[W]	50	85	50	85	50	85
Continuous stall current	$I_o$	[Arms]	4.35	7.26	2.18	2.72	0.60	0.6
Maximum current	$I_{Max}$	[Arms]	15.05	25.08	7.52	9.40	2.09	2.09
Nominal current	$I_n$	[Arms]	3.99	5.61	1.99	2.10	0.55	0.47
Nominal working speed	$n_N$	[rpm]	3000	6000	3000	6000	3000	6000
Maximum working speed	$n_{Max}$	[rpm]	6250	8000	6250	8000	8000	8000
Torque constant	$K_t$	[Nm/Arms]	0.041	0.025	0.083	0.066	0.298	0.298
Voltage constant	$K_{e\ u-v}$	[Vrms/krpm]	2.5	1.5	5.0	4.0	18.0	18.0
Winding resistance @ 20 °C	$R_{u-v}$	[Ohm]	0.556	0.183	2.235	1.408	27.712	27.712
Winding inductance	$L_{q\ u-v}$	[mH]	0.310	0.104	1.240	0.773	15.889	15.889
Electrical time constant	$T_e$	[ms]	0.56	0.57	0.55	0.55	0.57	0.57
Thermal resistance	$R_{th}$	[°C/W]	4.07					
Mechanical time constant (a)	$T_m$	[ms]	1.01	0.92	1.01	1.00	0.97	0.97
Rotor inertia without holding brake	$J$	[kg·cm <sup>2</sup> ]	0.0305					
Rotor inertia with holding brake	$J$	[kg·cm <sup>2</sup> ]	0.0326					
Mass without holding brake	$m$	[kg]	0.40					
Mass with holding brake	$m$	[kg]	0.56					
Max. axial shaft load 3000 / 6000 rpm	$SL_a$	[N]	45 / 35					
Max. radial shaft load 3000 / 6000 rpm	$SL_r$	[N]	120 / 95					

Rated output with 185 x 185 x 8 mm aluminium heat sink flange coupling. Derating must be considered if the oil seal is applied - IP 54 standard shaft bushing.  
(\*) without brake.  
(a) without brake and without feedback.

# TORQUE/SPEED CHARTS

## 401A 77

Operative curves at 24 Vdc

— Cn — Cmax

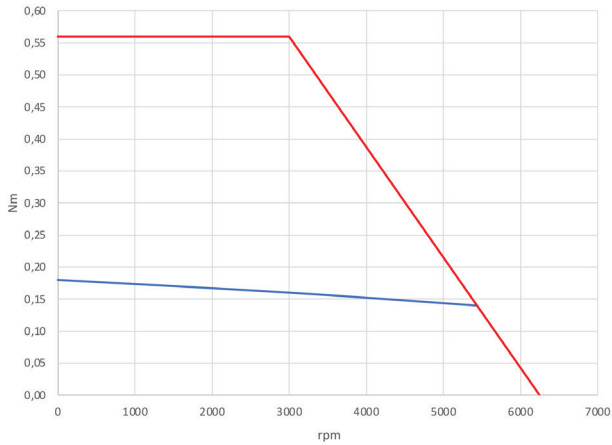

## 401A 41

Operative curves at 24 Vdc

— Cn — Cmax

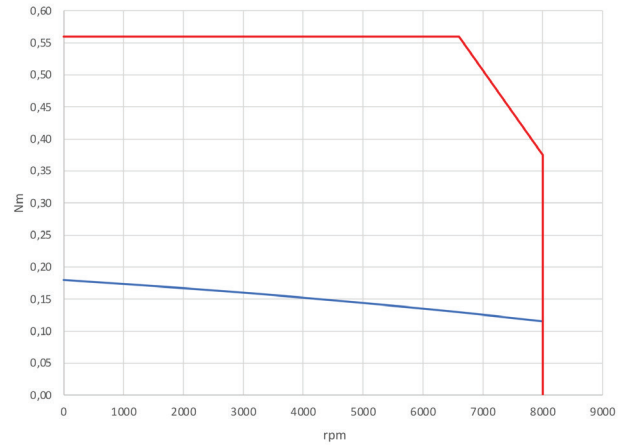

## 401A 78

Operative curves at 48 Vdc

— Cn — Cmax

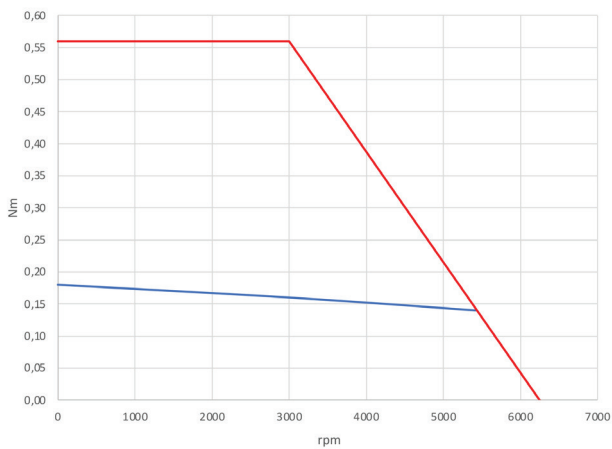

## 401A 33

Operative curves at 48 Vdc

— Cn — Cmax

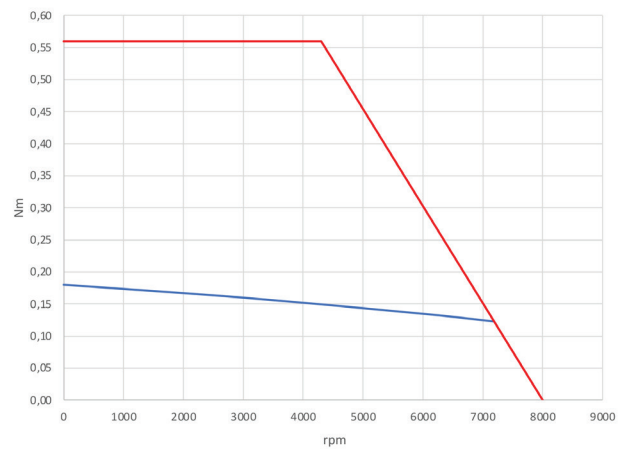

## 401A 09

Operative curves at 230 Vac

— Cn — Cmax

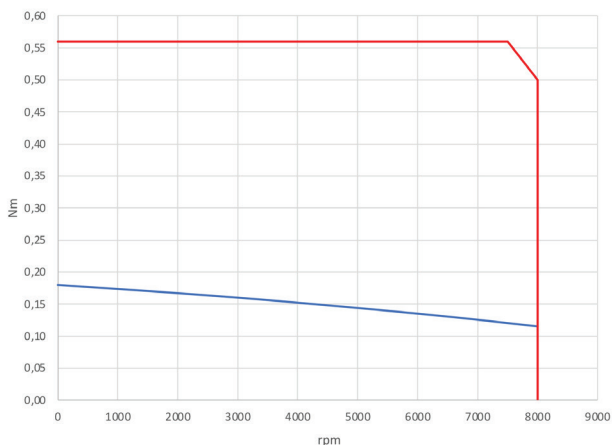

**Operative temperature -20 ÷ +40 °C**

Any specifications are subjected to change without notice.  
All rights reserved Motor Power Company®

# RATINGS and SPECIFICATION

			24 Vdc		48 Vdc		230 Vac	
TYPE OF WINDING			77	41	78	33	13	13
<b>ELECTRICAL DATA</b>								
Continuous stall torque (*)	$M_o$	[Nm]	0.33					
Peak torque	$M_{Max}$	[Nm]	1.12					
Nominal torque	$M_n$	[Nm]	0.32	0.28	0.32	0.28	0.32	0.28
Nominal power	$P_n$	[W]	100	175	100	175	100	175
Continuous stall current	$I_o$	[Arms]	7.98	13.30	3.99	4.99	0.73	0.73
Maximum current	$I_{Max}$	[Arms]	30.10	50.16	15.05	18.81	2.74	2.74
Nominal current	$I_n$	[Arms]	8.15	11.88	4.07	4.45	0.74	0.65
Nominal working speed	$n_N$	[rpm]	3000	6000	3000	6000	3000	6000
Maximum working speed	$n_{Max}$	[rpm]	6250	8000	6250	8000	7800	7800
Torque constant	$K_t$	[Nm/Arms]	0.041	0.025	0.083	0.066	0.455	0.455
Voltage constant	$K_{e\ u-v}$	[Vrms/krpm]	2.5	1.5	5.0	4.0	27.5	27.5
Winding resistance @ 20 °C	$R_{u-v}$	[Ohm]	0.253	0.087	1.019	0.632	30.848	30.848
Winding inductance	$L_{q\ u-v}$	[mH]	0.149	0.046	0.596	0.361	17.679	17.679
Electrical time constant	$T_e$	[ms]	0.59	0.53	0.59	0.57	0.57	0.57
Thermal resistance	$R_{th}$	[°C/W]	2.44					
Mechanical time constant (a)	$T_m$	[ms]	0.83	0.79	0.83	0.81	0.83	0.83
Rotor inertia without holding brake	$J$	[kg·cm <sup>2</sup> ]	0.0561					
Rotor inertia with holding brake	$J$	[kg·cm <sup>2</sup> ]	0.0580					
Mass without holding brake	$m$	[kg]	0.49					
Mass with holding brake	$m$	[kg]	0.68					
Max. axial shaft load 3000 / 6000 rpm	$SL_a$	[N]	45 / 35					
Max. radial shaft load 3000 / 6000 rpm	$SL_r$	[N]	120 / 95					

Rated output with 185 x 185 x 8 mm aluminium heat sink flange coupling. Derating must be considered if the oil seal is applied - IP 54 standard shaft bushing.

(\*) without brake.

(a) without brake and without feedback.



# TORQUE/SPEED CHARTS

## 401B 77

Operative curves at 24 Vdc — Cn — Cmax

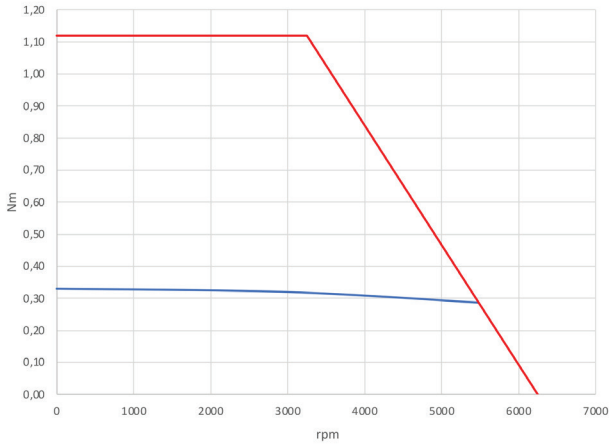

## 401B 41

Operative curves at 24 Vdc — Cn — Cmax

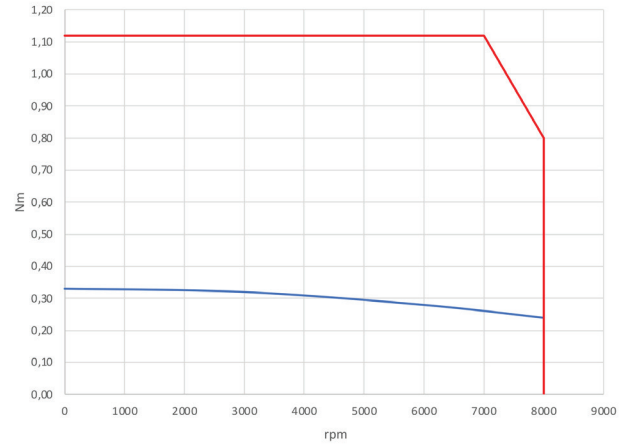

## 401B 78

Operative curves at 48 Vdc — Cn — Cmax

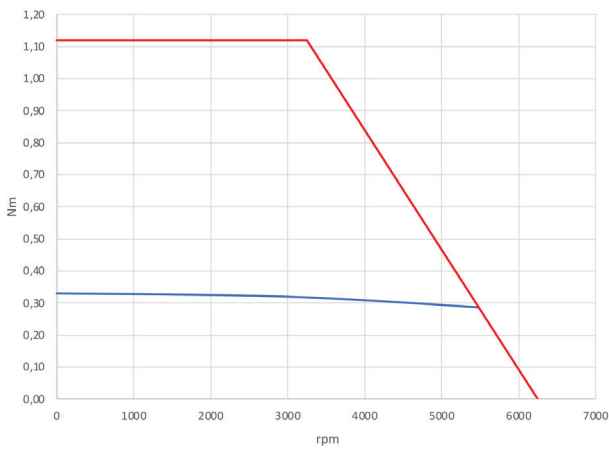

## 401B 33

Operative curves at 48 Vdc — Cn — Cmax

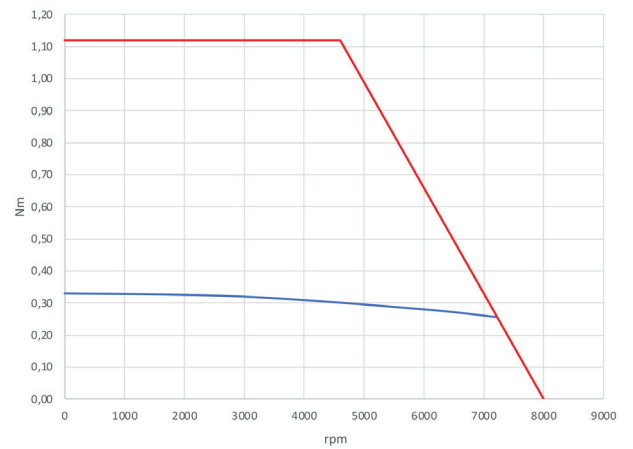

## 401B 13

Operative curves at 230 Vac — Cn — Cmax

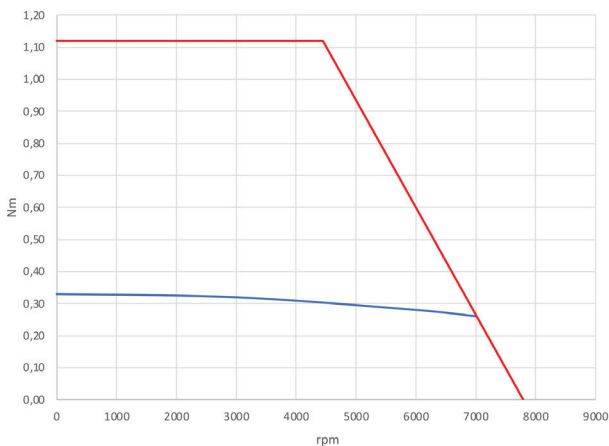

**Operative temperature -20 ÷ +40 °C**

Any specifications are subjected to change without notice.  
All rights reserved Motor Power Company®



MW  
P

TETRA  
COMPACT

4

60

			230 Vac		400 Vac	
TYPE OF WINDING			20	21	16	15
<b>ELECTRICAL DATA</b>						
Continuous stall torque (*)	$M_o$	[Nm]	0.67			
Peak torque	$M_{Max}$	[Nm]	2.24			
Nominal torque	$M_n$	[Nm]	0.64	0.56	0.64	0.56
Nominal power	$P_n$	[W]	200	350	200	350
Continuous stall current	$I_o$	[Arms]	0.92	1.27	0.56	0.74
Maximum current	$I_{Max}$	[Arms]	3.42	4.73	2.08	2.74
Nominal current	$I_n$	[Arms]	0.93	1.12	0.56	0.65
Nominal working speed	$n_N$	[rpm]	3000	6000	3000	6000
Maximum working speed	$n_{Max}$	[rpm]	4800	6800	5100	6800
Torque constant	$K_t$	[Nm/Arms]	0.728	0.526	1.2	0.91
Voltage constant	$K_{e\ u-v}$	[Vrms/krpm]	44.0	31.8	72.5	55
Winding resistance @ 20 °C	$R_{u-v}$	[Ohm]	20.367	10.260	52.39	31.805
Winding inductance	$L_{q\ u-v}$	[mH]	19.461	10.119	52.74	30.160
Electrical time constant	$T_e$	[ms]	0.96	0.99	1.01	0.95
Thermal resistance	$R_{th}$	[°C/W]	2.59			
Mechanical time constant (a)	$T_m$	[ms]	0.86	0.83	0.81	0.86
Rotor inertia without holding brake	$J$	[kg·cm <sup>2</sup> ]	0.223			
Rotor inertia with holding brake	$J$	[kg·cm <sup>2</sup> ]	0.236			
Mass without holding brake	$m$	[kg]	0.92			
Mass with holding brake	$m$	[kg]	1.44			
Max. axial shaft load 3000 / 6000 rpm	$SL_a$	[N]	42 / 32			
Max. radial shaft load 3000 / 6000 rpm	$SL_r$	[N]	260 / 200			

Rated output with 250 x 250 x 12 mm aluminium heat sink flange coupling. Derating must be considered if the oil seal is applied - IP 54 standard shaft bushing.  
 (\*) without brake.

(a) without brake and without feedback.



# TORQUE/SPEED CHARTS

## 602A 20

Operative curves at 230 Vac — Cn — Cmax

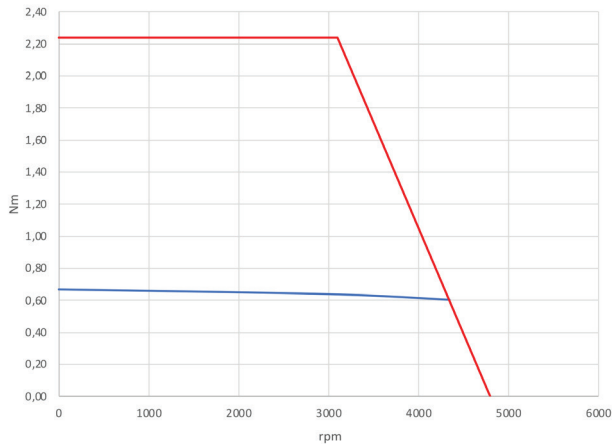

## 602A 21

Operative curves at 230 Vac — Cn — Cmax

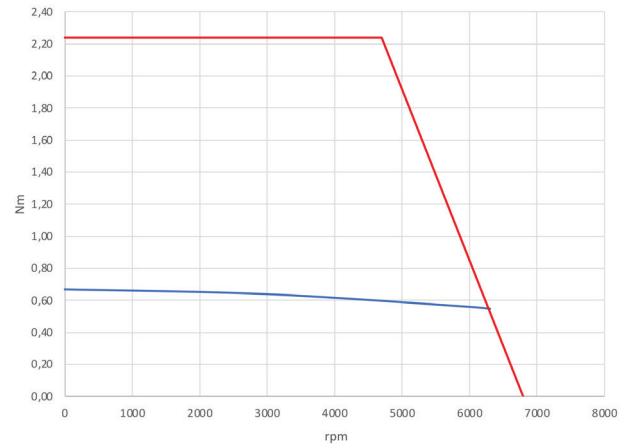

## 602A 16

Operative curves at 400 Vac — Cn — Cmax

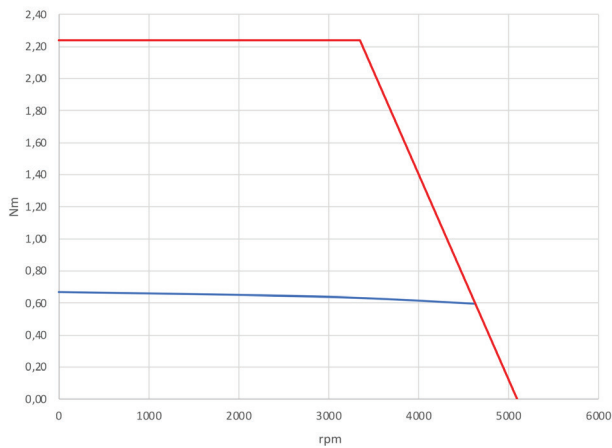

## 602A 15

Operative curves at 400 Vac — Cn — Cmax

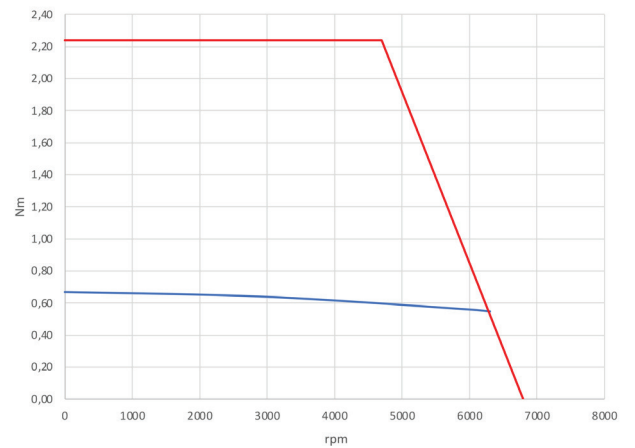

**Operative temperature -20 ÷ +40 °C**

Any specifications are subjected to change without notice.  
All rights reserved Motor Power Company®

			230 Vac		400 Vac	
TYPE OF WINDING			20	21	16	15
<b>ELECTRICAL DATA</b>						
Continuous stall torque (*)	$M_o$	[Nm]	1.38			
Peak torque	$M_{Max}$	[Nm]	4.44			
Nominal torque	$M_n$	[Nm]	1.27	0.95	1.27	0.95
Nominal power	$P_n$	[W]	400	600	400	600
Continuous stall current	$I_o$	[Arms]	1.90	2.62	1.15	1.52
Maximum current	$I_{Max}$	[Arms]	6.78	9.38	4.11	5.42
Nominal current	$I_n$	[Arms]	1.49	1.90	1.11	1.10
Nominal working speed	$n_N$	[rpm]	3000	6000	3000	6000
Maximum working speed	$n_{Max}$	[rpm]	4900	6800	5150	6800
Torque constant	$K_t$	[Nm/Arms]	0.728	0.526	1.2	0.91
Voltage constant	$K_{e\ u-v}$	[Vrms/krpm]	44.0	31.8	72.5	55
Winding resistance @ 20 °C	$R_{u-v}$	[Ohm]	7.869	4.120	20.926	12.598
Winding inductance	$L_{q\ u-v}$	[mH]	10.836	5.690	29.579	16.833
Electrical time constant	$T_e$	[ms]	1.38	1.38	1.41	1.34
Thermal resistance	$R_{th}$	[°C/W]	1.52			
Mechanical time constant (a)	$T_m$	[ms]	0.57	0.57	0.56	0.59
Rotor inertia without holding brake	$J$	[kg·cm <sup>2</sup> ]	0.414			
Rotor inertia with holding brake	$J$	[kg·cm <sup>2</sup> ]	0.427			
Mass without holding brake	$m$	[kg]	1.33			
Mass with holding brake	$m$	[kg]	1.85			
Max. axial shaft load 3000 / 6000 rpm	$SL_a$	[N]	42 / 32			
Max. radial shaft load 3000 / 6000 rpm	$SL_r$	[N]	260 / 200			

Rated output with 250 x 250 x 12 mm aluminium heat sink flange coupling. Derating must be considered if the oil seal is applied - IP 54 standard shaft bushing.

(\*) without brake.

(a) without brake and without feedback.

# TORQUE/SPEED CHARTS

## 602B 20

Operative curves at 230 Vac — Cn — Cmax

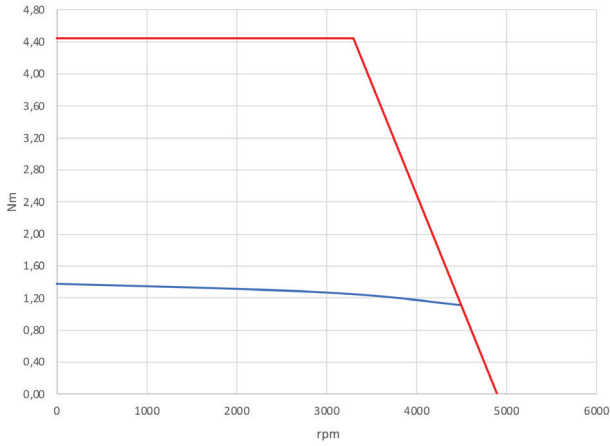

## 602B 21

Operative curves at 230 Vac — Cn — Cmax

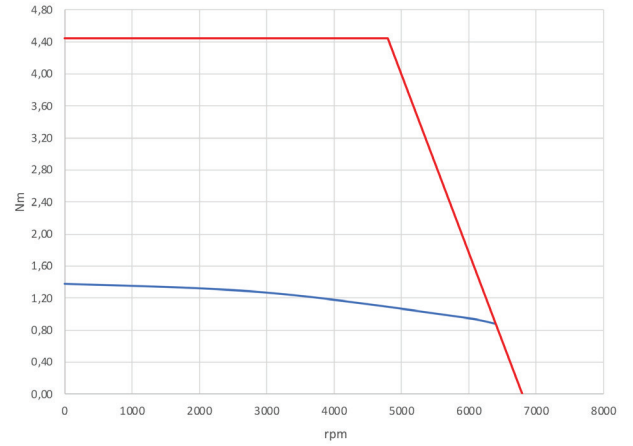

## 602B 16

Operative curves at 400 Vac — Cn — Cmax

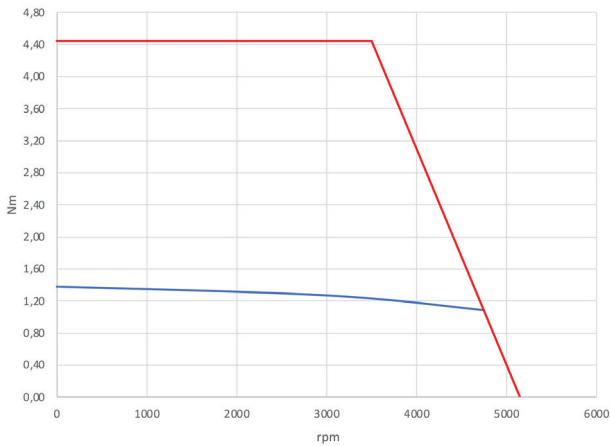

## 602B 15

Operative curves at 400 Vac — Cn — Cmax

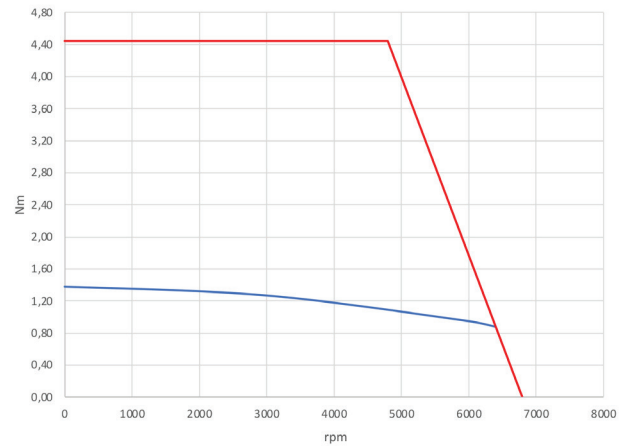

**Operative temperature -20 ÷ +40 °C**

Any specifications are subjected to change without notice.  
All rights reserved Motor Power Company®





MW  
P

TETRA  
COMPACT 4 80

			230 Vac		400 Vac	
TYPE OF WINDING			20	21	16	15
<b>ELECTRICAL DATA</b>						
Continuous stall torque (*)	$M_o$	[Nm]	1.38			
Peak torque	$M_{Max}$	[Nm]	4.44			
Nominal torque	$M_n$	[Nm]	1.27	1.12	1.27	1.12
Nominal power	$P_n$	[W]	400	700	400	700
Continuous stall current	$I_o$	[Arms]	1.90	2.62	1.15	1.52
Maximum current	$I_{Max}$	[Arms]	6.78	9.38	4.11	5.42
Nominal current	$I_n$	[Arms]	1.84	2.24	1.11	1.3
Nominal working speed	$n_N$	[rpm]	3000	6000	3000	6000
Maximum working speed	$n_{Max}$	[rpm]	4900	6800	5200	6800
Torque constant	$K_t$	[Nm/Arms]	0.728	0.526	1.2	0.91
Voltage constant	$K_{e\ u-v}$	[Vrms/krpm]	44.0	31.8	72.5	55
Winding resistance @ 20 °C	$R_{u-v}$	[Ohm]	6.125	3.080	15.840	9.45
Winding inductance	$L_{q\ u-v}$	[mH]	11.766	6.170	32.235	18.385
Electrical time constant	$T_e$	[ms]	1.92	2.00	2.04	1.95
Thermal resistance	$R_{th}$	[°C/W]	1.97			
Mechanical time constant (a)	$T_m$	[ms]	0.93	0.89	0.88	0.92
Rotor inertia without holding brake	$J$	[kg·cm <sup>2</sup> ]	0.79			
Rotor inertia with holding brake	$J$	[kg·cm <sup>2</sup> ]	0.86			
Mass without holding brake	$m$	[kg]	1.83			
Mass with holding brake	$m$	[kg]	2.62			
Max. axial shaft load 3000 / 6000 rpm	$SL_a$	[N]	115 / 90			
Max. radial shaft load 3000 / 6000 rpm	$SL_r$	[N]	440 / 350			

Rated output with 250 x 250 x 12 mm aluminium heat sink flange coupling. Derating must be considered if the oil seal is applied - IP 54 standard shaft bushing.

(\*) without brake.

(a) without brake and without feedback.

# TORQUE/SPEED CHARTS

## 803A 20

Operative curves at 230 Vac — Cn — Cmax

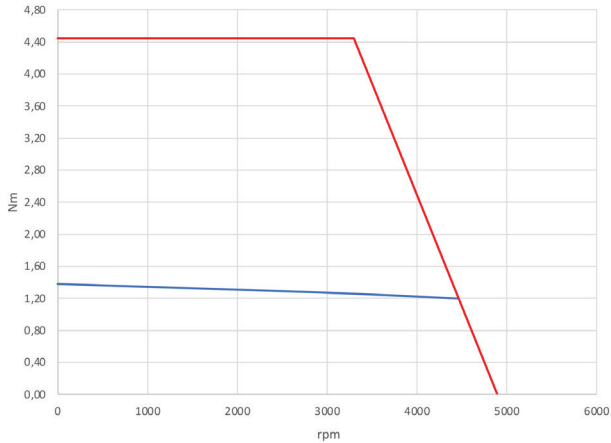

## 803A 21

Operative curves at 230 Vac — Cn — Cmax



## 803A 16

Operative curves at 400 Vac — Cn — Cmax

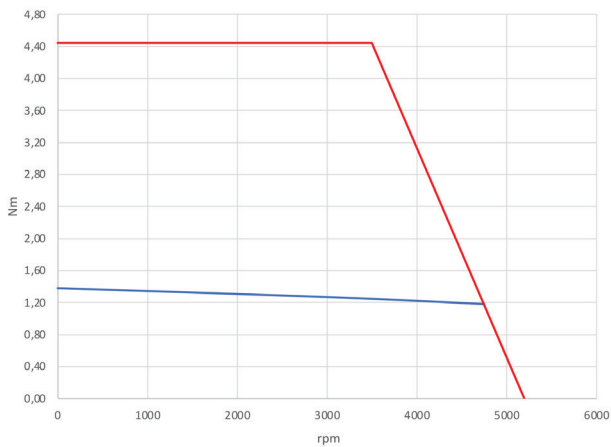

## 803A 15

Operative curves at 400 Vac — Cn — Cmax

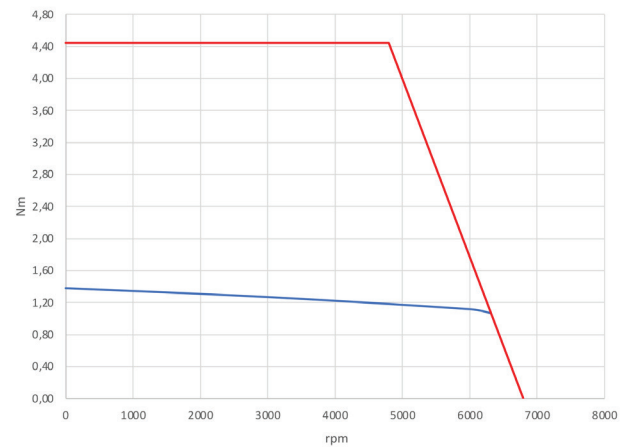

**Operative temperature -20 ÷ +40 °C**

Any specifications are subjected to change without notice.  
All rights reserved Motor Power Company®

			230 Vac		400 Vac	
TYPE OF WINDING			20	21	16	15
<b>ELECTRICAL DATA</b>						
Continuous stall torque (*)	$M_o$	[Nm]	2.64			
Peak torque	$M_{Max}$	[Nm]	8.33			
Nominal torque	$M_n$	[Nm]	2.38	1.75	2.38	1.75
Nominal power	$P_n$	[W]	750	1100	750	1100
Continuous stall current	$I_o$	[Arms]	3.63	5.02	2.20	2.90
Maximum current	$I_{Max}$	[Arms]	12.72	17.60	7.72	10.17
Nominal current	$I_n$	[Arms]	3.44	3.50	2.09	2.02
Nominal working speed	$n_N$	[rpm]	3000	6000	3000	6000
Maximum working speed	$n_{Max}$	[rpm]	4900	6800	5350	6800
Torque constant	$K_t$	[Nm/Arms]	0.728	0.526	1.2	0.91
Voltage constant	$K_{e\ u-v}$	[Vrms/krpm]	44.0	31.8	72.5	55
Winding resistance @ 20 °C	$R_{u-v}$	[Ohm]	2.351	1.216	6.319	3.794
Winding inductance	$L_{q\ u-v}$	[mH]	4.785	2.544	13.291	7.728
Electrical time constant	$T_e$	[ms]	2.04	2.09	2.10	2.04
Thermal resistance	$R_{th}$	[°C/W]	1.35			
Mechanical time constant (a)	$T_m$	[ms]	0.61	0.61	0.61	0.63
Rotor inertia without holding brake	$J$	[kg·cm <sup>2</sup> ]	1.42			
Rotor inertia with holding brake	$J$	[kg·cm <sup>2</sup> ]	1.50			
Mass without holding brake	$m$	[kg]	2.76			
Mass with holding brake	$m$	[kg]	3.37			
Max. axial shaft load 3000 / 6000 rpm	$SL_a$	[N]	115 / 90			
Max. radial shaft load 3000 / 6000 rpm	$SL_r$	[N]	440 / 350			

Rated output with 250 x 250 x 12 mm aluminium heat sink flange coupling. Derating must be considered if the oil seal is applied - IP 54 standard shaft bushing. (\*) without brake.

(a) without brake and without feedback.

# TORQUE/SPEED CHARTS

## 803B 20

Operative curves at 230 Vac — Cn — Cmax

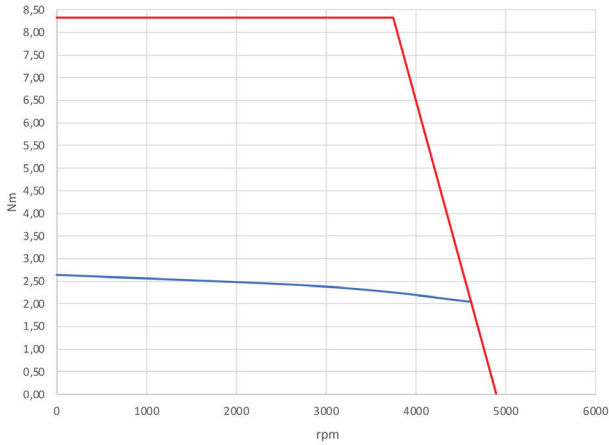

## 803B 21

Operative curves at 230 Vac — Cn — Cmax

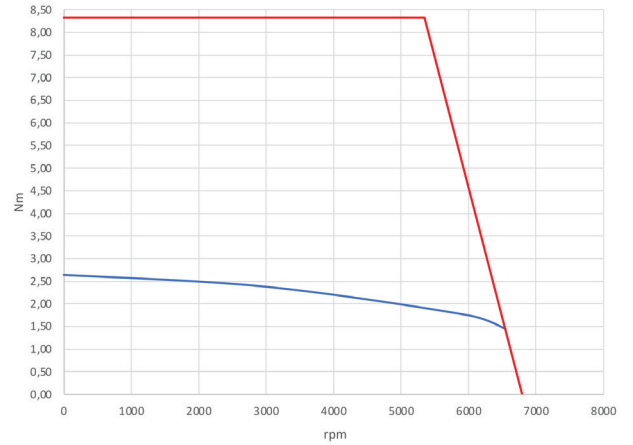

## 803B 16

Operative curves at 400 Vac — Cn — Cmax

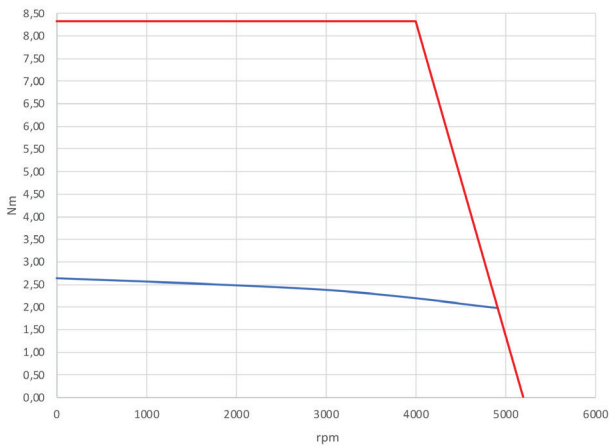

## 803B 15

Operative curves at 400 Vac — Cn — Cmax

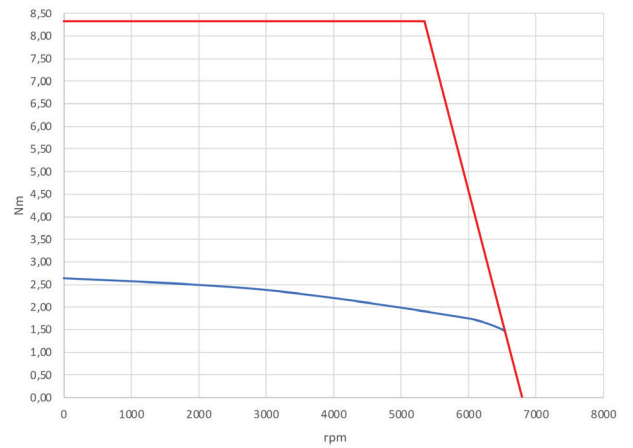

**Operative temperature -20 ÷ +40 °C**

Any specifications are subjected to change without notice.  
All rights reserved Motor Power Company®



			230 Vac		400 Vac	
TYPE OF WINDING			20	21	16	15
<b>ELECTRICAL DATA</b>						
Continuous stall torque (*)	$M_o$	[Nm]	3.54			
Peak torque	$M_{Max}$	[Nm]	11.1			
Nominal torque	$M_n$	[Nm]	3.18	2.10	3.18	2.10
Nominal power	$P_n$	[W]	1000	1300	1000	1300
Continuous stall current	$I_o$	[Arms]	4.86	6.73	2.95	3.89
Maximum current	$I_{Max}$	[Arms]	16.95	23.45	10.29	13.56
Nominal current	$I_n$	[Arms]	4.50	4.12	2.73	2.43
Nominal working speed	$n_N$	[rpm]	3000	6000	3000	6000
Maximum working speed	$n_{Max}$	[rpm]	4900	6800	5200	6800
Torque constant	$K_t$	[Nm/Arms]	0.728	0.526	1.2	0.91
Voltage constant	$K_{e\ u-v}$	[Vrms/krpm]	44.0	31.8	72.5	55
Winding resistance @ 20 °C	$R_{u-v}$	[Ohm]	1.369	0.726	3.648	2.189
Winding inductance	$L_{q\ u-v}$	[mH]	3.729	2.025	10.250	5.950
Electrical time constant	$T_e$	[ms]	2.72	2.79	2.81	2.72
Thermal resistance	$R_{th}$	[°C/W]	1.25			
Mechanical time constant (a)	$T_m$	[ms]	0.52	0.53	0.51	0.53
Rotor inertia without holding brake	$J$	[kg·cm <sup>2</sup> ]	2.03			
Rotor inertia with holding brake	$J$	[kg·cm <sup>2</sup> ]	2.11			
Mass without holding brake	$m$	[kg]	3.25			
Mass with holding brake	$m$	[kg]	3.87			
Max. axial shaft load 3000 / 6000 rpm	$SL_a$	[N]	115 / 90			
Max. radial shaft load 3000 / 6000 rpm	$SL_r$	[N]	440 / 350			

Rated output with 250 x 250 x 12 mm aluminium heat sink flange coupling. Derating must be considered if the oil seal is applied - IP 54 standard shaft bushing.

(\*) without brake.

(a) without brake and without feedback.

# TORQUE/SPEED CHARTS

## 803C 20

Operative curves at 230 Vac — Cn — Cmax

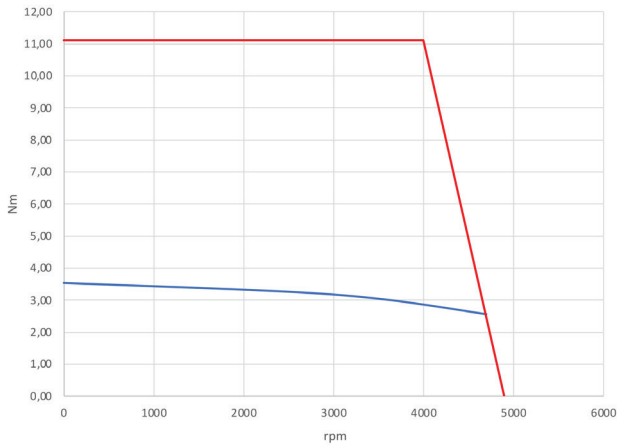

## 803C 21

Operative curves at 230 Vac — Cn — Cmax

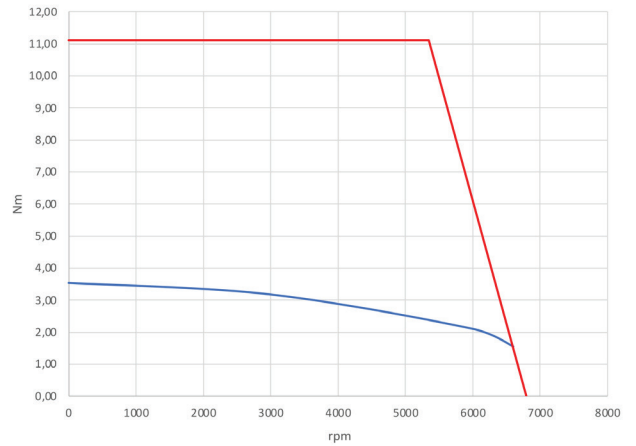

## 803C 16

Operative curves at 400 Vac — Cn — Cmax

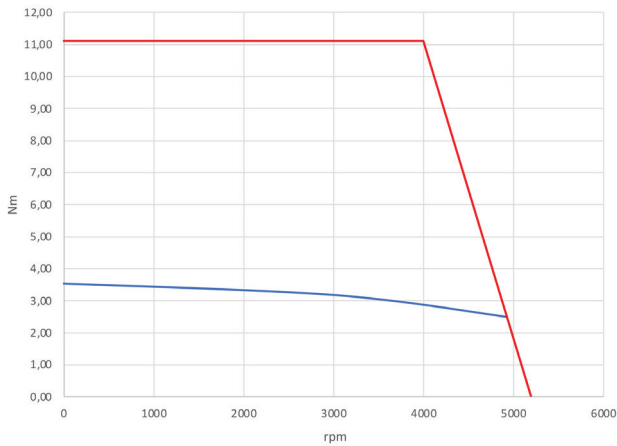

## 803C 15

Operative curves at 400 Vac — Cn — Cmax

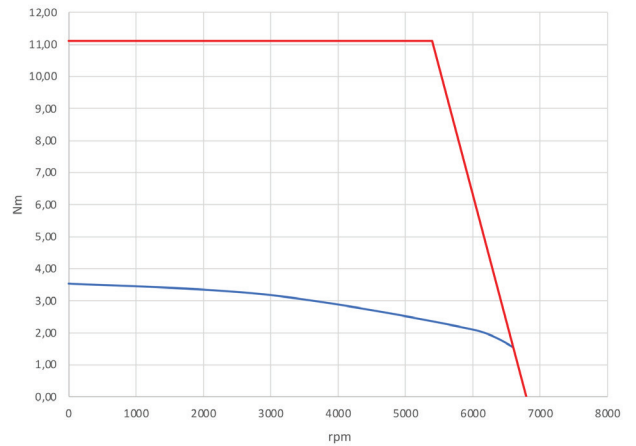

**Operative temperature -20 ÷ +40 °C**

Any specifications are subjected to change without notice.  
All rights reserved Motor Power Company®



MW  
P

TETRA  
COMPACT

4

100

## 100 4A RATINGS and SPECIFICATION

			230 Vac		400 Vac	
TYPE OF WINDING			D1	15	D6	17
<b>ELECTRICAL DATA</b>						
Continuous stall torque (*)	$M_o$	[Nm]	4.0			
Peak torque	$M_{Max}$	[Nm]	16.5			
Nominal torque	$M_n$	[Nm]	3.18			
Nominal power	$P_n$	[W]	1000			
Continuous stall current	$I_o$	[Arms]	7.33	4.40	5.06	2.50
Maximum current	$I_{Max}$	[Arms]	35.56	21.34	20.83	12.14
Nominal current	$I_n$	[Arms]	6.26	3.76	5.77	2.14
Nominal working speed	$n_N$	[rpm]	3000			
Maximum working speed	$n_{Max}$	[rpm]	6000	3900	6000	3900
Torque constant	$K_t$	[Nm/Arms]	0.55	0.91	0.63	1.60
Voltage constant	$K_{e\ u-v}$	[Vrms/krpm]	33.0	55.0	38.0	96.7
Winding resistance @ 20 °C	$R_{u-v}$	[Ohm]	0.64	1.82	0.80	5.12
Winding inductance	$L_{q\ u-v}$	[mH]	4.85	13.50	6.30	41.30
Electrical time constant	$T_e$	[ms]	7.6	7.4	7.8	8.1
Thermal resistance	$R_{th}$	[°C/W]	1.23			
Mechanical time constant (a)	$T_m$	[ms]	0.54	0.56	0.51	0.51
Rotor inertia without holding brake	$J$	[kg·cm <sup>2</sup> ]	2.53			
Rotor inertia with holding brake	$J$	[kg·cm <sup>2</sup> ]	2.65			
Mass without holding brake	$m$	[kg]	5.55			
Mass with holding brake	$m$	[kg]	6.60			
Max. axial shaft load 3000 / 5000 rpm	$SL_a$	[N]	245 / 220			
Max. radial shaft load 3000 / 5000 rpm	$SL_r$	[N]	690 / 580			

Rated output with 300 x 300 x 20 mm aluminium heat sink flange. Derating must be considered if the oil seal is applied - IP 54 standard shaft bushing.

(\*) without brake.

(a) without brake and without feedback.

# TORQUE/SPEED CHARTS

## 1004A D1

Operative curves at 230 Vac — Cn — Cmax

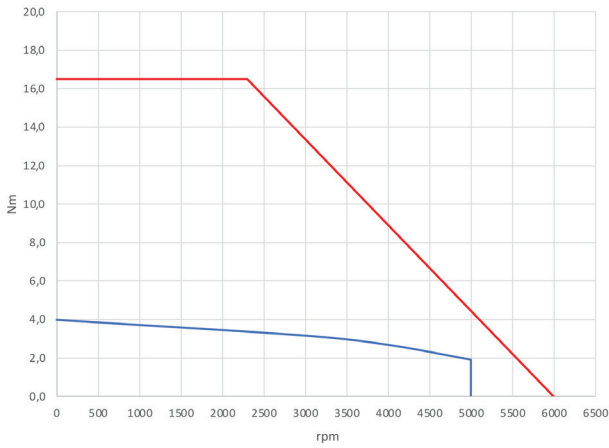

## 1004A 15

Operative curves at 230 Vac — Cn — Cmax

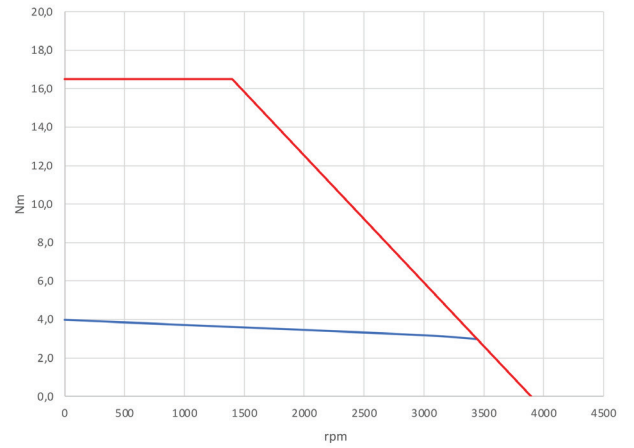

## 1004A D6

Operative curves at 400 Vac — Cn — Cmax

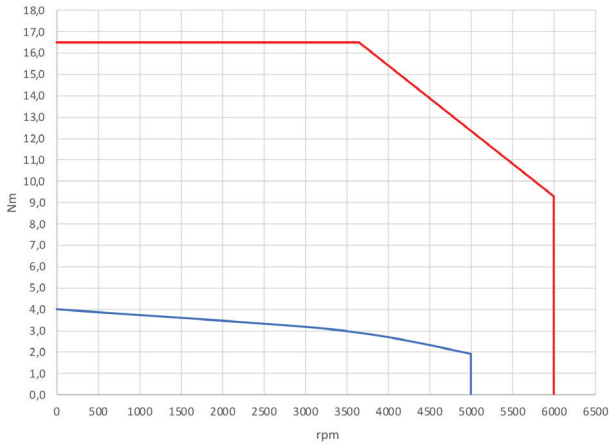

## 1004A 17

Operative curves at 400 Vac — Cn — Cmax

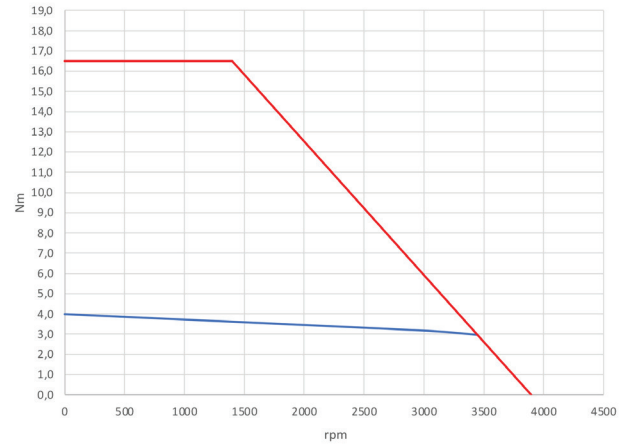

**Operative temperature -20 ÷ +40 °C**

Any specifications are subjected to change without notice.  
All rights reserved Motor Power Company®



## 100 4B RATINGS and SPECIFICATION

			230 Vac		400 Vac	
TYPE OF WINDING			D5	15	H3	17
<b>ELECTRICAL DATA</b>						
Continuous stall torque (*)	$M_o$	[Nm]	8.3			
Peak torque	$M_{Max}$	[Nm]	33.0			
Nominal torque	$M_n$	[Nm]	6.37			
Nominal power	$P_n$	[W]	2000			
Continuous stall current	$I_o$	[Arms]	12.87	9.12	6.97	5.19
Maximum current	$I_{Max}$	[Arms]	60.19	42.68	32.60	24.27
Nominal current	$I_n$	[Arms]	10.62	7.53	5.75	4.28
Nominal working speed	$n_N$	[rpm]	3000			
Maximum working speed	$n_{Max}$	[rpm]	5250	3900	5000	3900
Torque constant	$K_t$	[Nm/Arms]	0.65	0.91	1.19	1.60
Voltage constant	$K_{e\ u-v}$	[Vrms/krpm]	39.0	55.0	72.0	96.7
Winding resistance @ 20 °C	$R_{u-v}$	[Ohm]	0.32	0.64	1.04	2.01
Winding inductance	$L_{q\ u-v}$	[mH]	2.45	4.87	8.35	15.14
Electrical time constant	$T_e$	[ms]	7.5	7.6	8.0	7.5
Thermal resistance	$R_{th}$	[°C/W]	0.78			
Mechanical time constant (a)	$T_m$	[ms]	0.36	0.35	0.34	0.36
Rotor inertia without holding brake	$J$	[kg·cm <sup>2</sup> ]	4.61			
Rotor inertia with holding brake	$J$	[kg·cm <sup>2</sup> ]	4.73			
Mass without holding brake	$m$	[kg]	8.09			
Mass with holding brake	$m$	[kg]	9.14			
Max. axial shaft load 3000 / 5000 rpm	$SL_a$	[N]	245 / 220			
Max. radial shaft load 3000 / 5000 rpm	$SL_r$	[N]	690 / 580			

Rated output with 300 x 300 x 20 mm aluminium heat sink flange. Derating must be considered if the oil seal is applied - IP 54 standard shaft bushing.

(\*) without brake.

(a) without brake and without feedback.

# TORQUE/SPEED CHARTS

## 1004B D5

Operative curves at 230 Vac

— Cn — Cmax

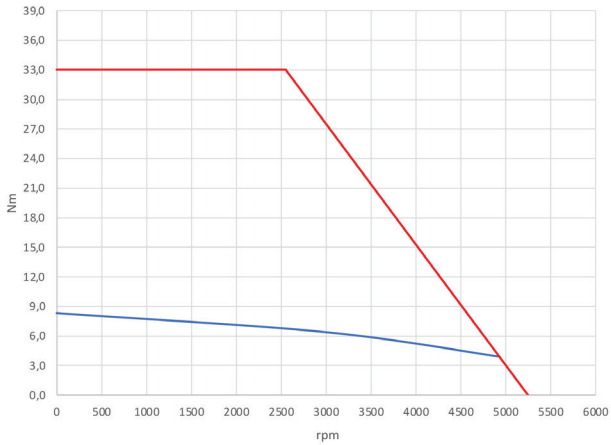

## 1004B 15

Operative curves at 230 Vac

— Cn — Cmax

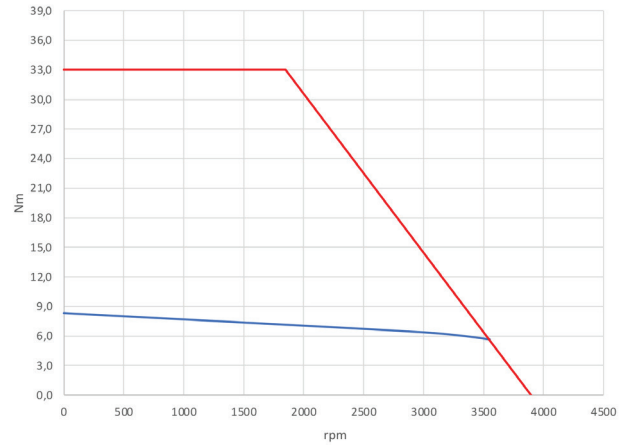

## 1004B H3

Operative curves at 400 Vac

— Cn — Cmax

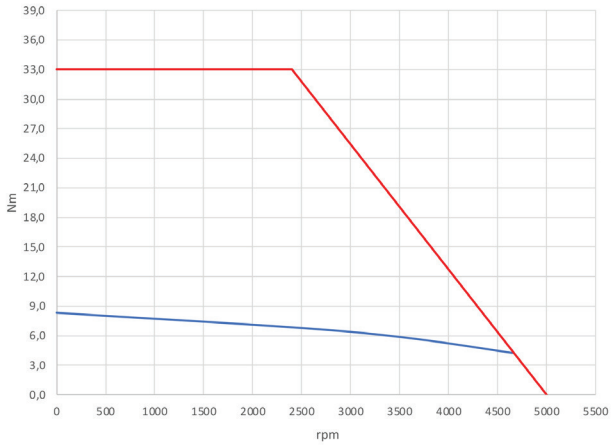

## 1004B 17

Operative curves at 400 Vac

— Cn — Cmax

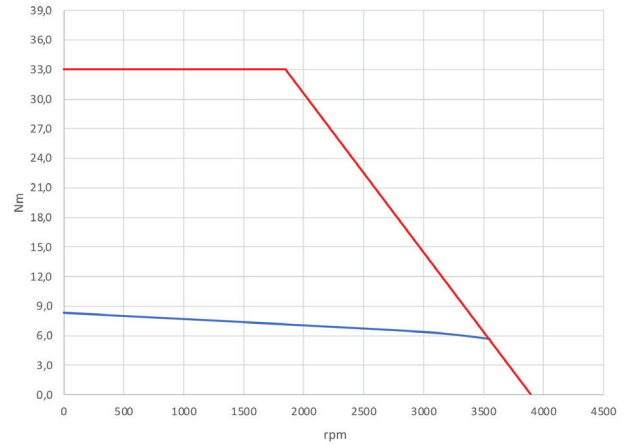

### Operative temperature -20 ÷ +40 °C

Any specifications are subjected to change without notice.  
All rights reserved Motor Power Company®

# TC4

# 100

## EXTERNAL DIMENSIONS

### G2/H2 connection

Model	Feedback tipe	L [mm]	L with brake [mm]	Z [mm]	Z with brake [mm]
4A	A1-M1-M2-R1	173.0	203.0	103.5	103.5
4B	A1-M1-M2-R1	218.0	248.0	149.0	149.0

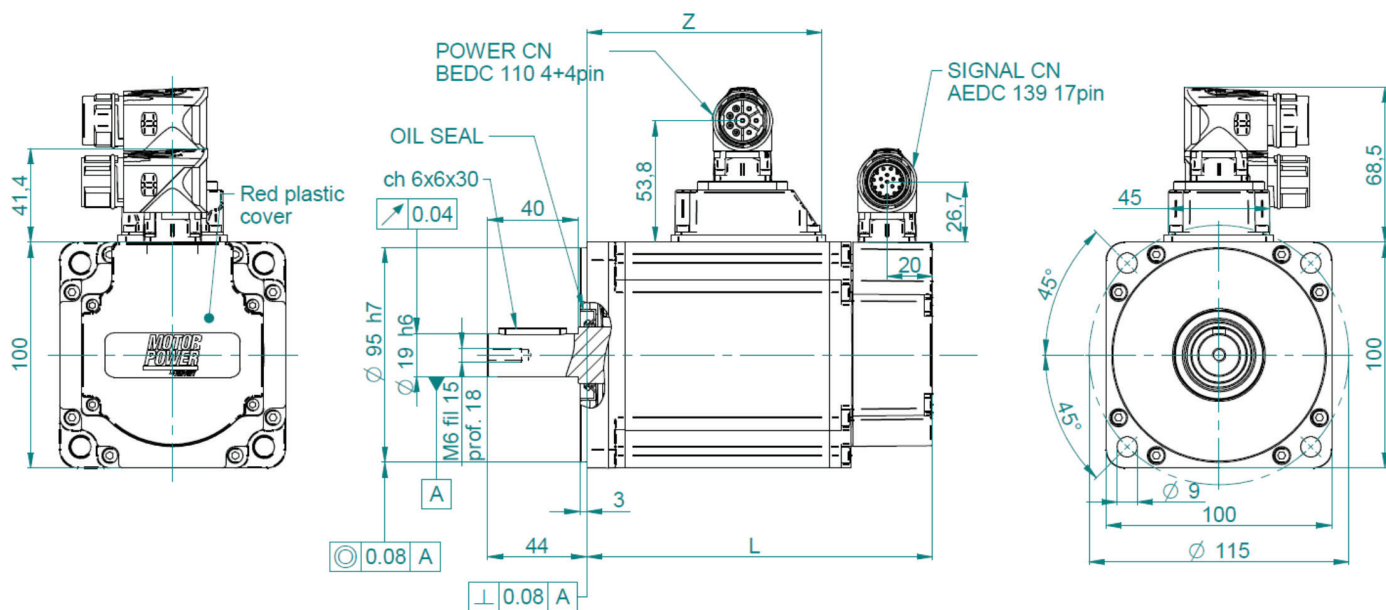

MW  
P

TETRA  
COMPACT

4

130

## 130 5F RATINGS and SPECIFICATION

	TYPE OF WINDING	230/400 Vac	
		F1	
<b>ELECTRICAL DATA</b>			
Continuous stall torque (*)	$M_o$	[Nm]	4.77
Peak torque	$M_{Max}$	[Nm]	14.3
Nominal torque	$M_n$	[Nm]	3.18
Nominal power	$P_n$	[W]	1000
Continuous stall current	$I_o$	[Arms]	5.77
Maximum current	$I_{Max}$	[Arms]	19.2
Nominal current	$I_n$	[Arms]	4.14
Nominal working speed	$n_N$	[rpm]	3000
Maximum working speed	$n_{Max}$	[rpm]	4000
Torque constant	$K_t$	[Nm/Arms]	0.83
Voltage constant	$K_{e\ u-v}$	[Vrms/krpm]	50
Winding resistance @ 20 °C	$R_{u-v}$	[Ohm]	0.71
Winding inductance	$L_{q\ u-v}$	[mH]	7.84
Electrical time constant	$T_e$	[ms]	11.1
Thermal resistance	$R_{th}$	[°C/W]	-
Mechanical time constant (a)	$T_m$	[ms]	0.69
Rotor inertia without holding brake	$J$	[kg·cm <sup>2</sup> ]	6.70
Rotor inertia with holding brake	$J$	[kg·cm <sup>2</sup> ]	7.95
Mass without holding brake	$m$	[kg]	7.35
Mass with holding brake	$m$	[kg]	8.87
Max. axial shaft load 2000 rpm	$SL_a$	[N]	230
Max. radial shaft load 2000 rpm	$SL_r$	[N]	1200

Rated output with 400 x 400 x 20 mm aluminium heat sink flange. Derating must be considered if the oil seal is applied - IP 54 standard shaft bushing.  
 (\*) without brake. (a) without brake and without feedback.

## TORQUE/SPEED CHARTS

**Operative temperature -20 ÷ +40 °C**

Any specifications are subjected to change without notice.  
 All rights reserved Motor Power Company®

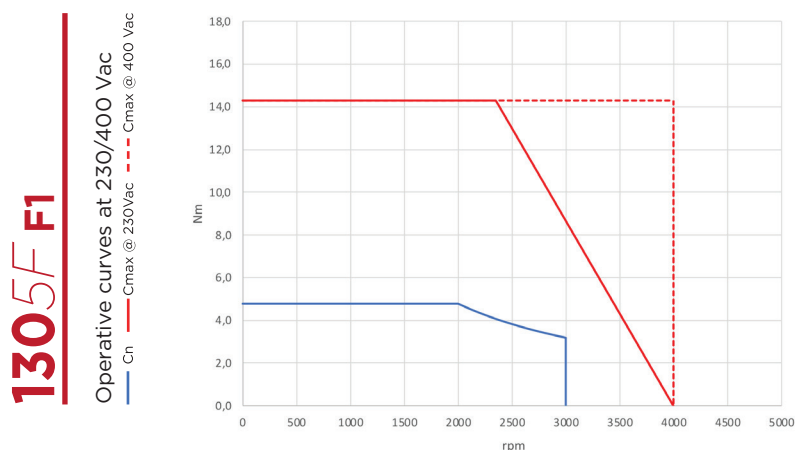

## 130 5G RATINGS and SPECIFICATION

	TYPE OF WINDING	230/400 Vac	
			H1
<b>ELECTRICAL DATA</b>			
Continuous stall torque (*)	$M_o$	[Nm]	7.16
Peak torque	$M_{Max}$	[Nm]	21.48
Nominal torque	$M_n$	[Nm]	4.78
Nominal power	$P_n$	[W]	1500
Continuous stall current	$I_o$	[Arms]	6.18
Maximum current	$I_{Max}$	[Arms]	20.6
Nominal current	$I_n$	[Arms]	4.44
Nominal working speed	$n_N$	[rpm]	3000
Maximum working speed	$n_{Max}$	[rpm]	4000
Torque constant	$K_t$	[Nm/Arms]	1.16
Voltage constant	$K_{e\ u-v}$	[Vrms/krpm]	70
Winding resistance @ 20 °C	$R_{u-v}$	[Ohm]	0.64
Winding inductance	$L_{q\ u-v}$	[mH]	7.2
Electrical time constant	$T_e$	[ms]	11.25
Thermal resistance	$R_{th}$	[°C/W]	-
Mechanical time constant (a)	$T_m$	[ms]	0.46
Rotor inertia without holding brake	$J$	[kg·cm <sup>2</sup> ]	9.72
Rotor inertia with holding brake	$J$	[kg·cm <sup>2</sup> ]	10.98
Mass without holding brake	$m$	[kg]	8.80
Mass with holding brake	$m$	[kg]	10.32
Max. axial shaft load 2000 rpm	$SL_a$	[N]	230
Max. radial shaft load 2000 rpm	$SL_r$	[N]	1200

Rated output with 400 x 400 x 20 mm aluminium heat sink flange. Derating must be considered if the oil seal is applied - IP 54 standard shaft bushing.  
 (\*) without brake. (a) without brake and without feedback.

## TORQUE/SPEED CHARTS

### Operative temperature -20 ÷ +40 °C

Any specifications are subjected to change without notice.  
 All rights reserved Motor Power Company®

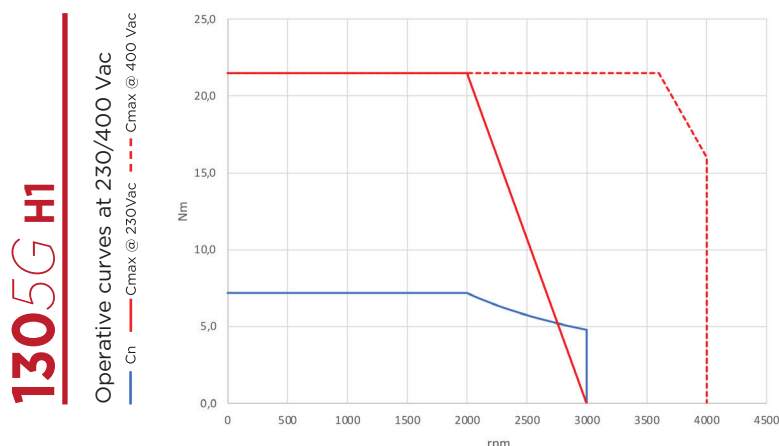

## 130 5H RATINGS and SPECIFICATION

	TYPE OF WINDING	230/400 Vac	
		22	
<b>ELECTRICAL DATA</b>			
Continuous stall torque (*)	$M_o$	[Nm]	9.55
Peak torque	$M_{Max}$	[Nm]	28.65
Nominal torque	$M_n$	[Nm]	6.37
Nominal power	$P_n$	[W]	2000
Continuous stall current	$I_o$	[Arms]	9.95
Maximum current	$I_{Max}$	[Arms]	33.2
Nominal current	$I_n$	[Arms]	7.14
Nominal working speed	$n_N$	[rpm]	3000
Maximum working speed	$n_{Max}$	[rpm]	4000
Torque constant	$K_t$	[Nm/Arms]	0.96
Voltage constant	$K_{e\ u-v}$	[Vrms/krpm]	58
Winding resistance @ 20 °C	$R_{u-v}$	[Ohm]	0.46
Winding inductance	$L_{q\ u-v}$	[mH]	5.8
Electrical time constant	$T_e$	[ms]	12.7
Thermal resistance	$R_{th}$	[°C/W]	-
Mechanical time constant (a)	$T_m$	[ms]	0.63
Rotor inertia without holding brake	$J$	[kg·cm <sup>2</sup> ]	12.77
Rotor inertia with holding brake	$J$	[kg·cm <sup>2</sup> ]	14.04
Mass without holding brake	$m$	[kg]	10.54
Mass with holding brake	$m$	[kg]	12.68
Max. axial shaft load 2000 rpm	$SL_a$	[N]	230
Max. radial shaft load 2000 rpm	$SL_r$	[N]	1200

Rated output with 400 x 400 x 20 mm aluminium heat sink flange. Derating must be considered if the oil seal is applied - IP 54 standard shaft bushing.  
 (\*) without brake. (a) without brake and without feedback.

## TORQUE/SPEED CHARTS

**Operative temperature -20 ÷ +40 °C**

Any specifications are subjected to change without notice.  
 All rights reserved Motor Power Company®

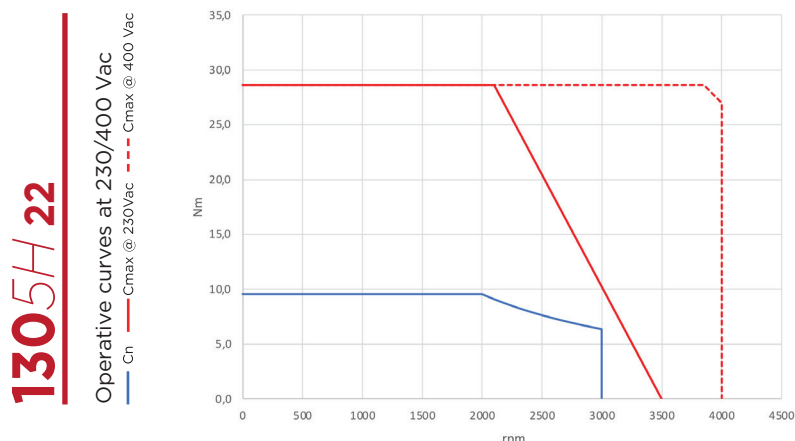



# EXTERNAL DIMENSIONS 130

## G2/H2 connection

Model	Feedback type	L [mm]	L with brake [mm]	Z [mm]	Z with brake [mm]
5F	A1-M1-M2-R1	162.0	191.0	94.5	94.5
5G	A1-M1-M2-R1	178.0	207.0	110.5	110.5
5H	A1-M1-M2-R1	202.0	231.0	134.5	134.5

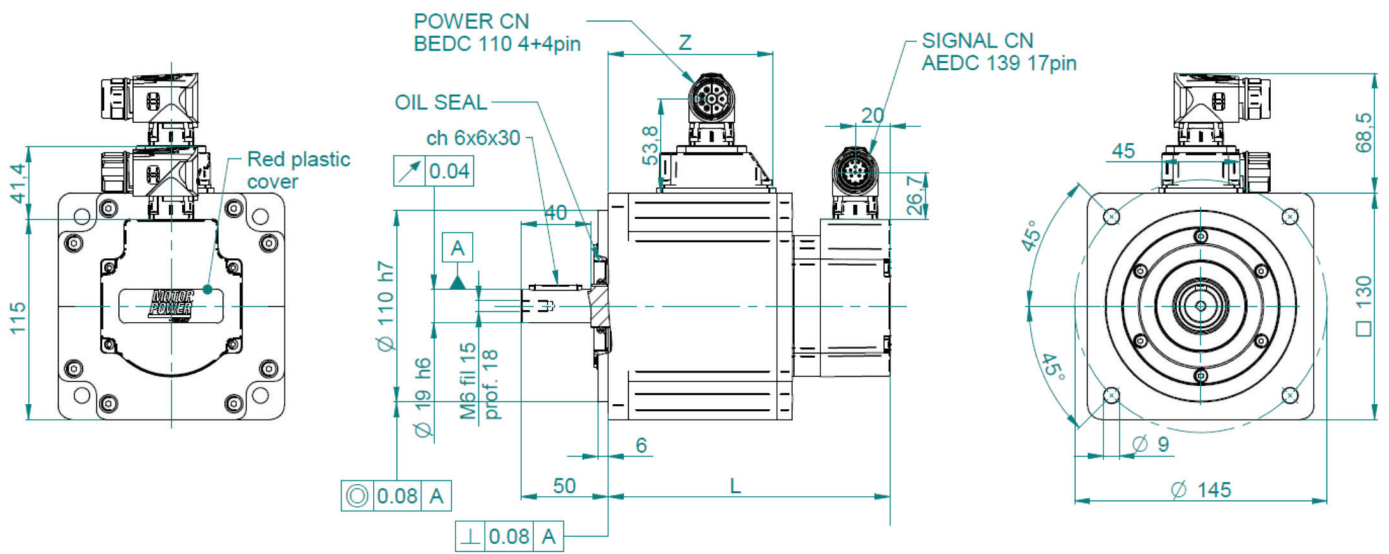



MW  
P

TETRA  
COMPACT

4

150

## 150 6A RATINGS and SPECIFICATION

TYPE OF WINDING	230 Vac		400 Vac	
	20		70	
<b>ELECTRICAL DATA</b>				
Continuous stall torque (*)	$M_o$	[Nm]	9.55	
Peak torque	$M_{Max}$	[Nm]	33.425	
Nominal torque	$M_n$	[Nm]	7.96	
Nominal power	$P_n$	[W]	2500	
Continuous stall current	$I_o$	[Arms]	13.12	7.70
Maximum current	$I_{Max}$	[Arms]	51.03	29.94
Nominal current	$I_n$	[Arms]	11.76	6.90
Nominal working speed	$n_N$	[rpm]	3000	
Maximum working speed	$n_{Max}$	[rpm]	4000	4000
Torque constant	$K_t$	[Nm/Arms]	0.73	1.24
Voltage constant	$K_{e\ u-v}$	[Vrms/krpm]	44.0	75.0
Winding resistance @ 20 °C	$R_{u-v}$	[Ohm]	0.18	0.54
Winding inductance	$L_{q\ u-v}$	[mH]	2.54	7.35
Electrical time constant	$T_e$	[ms]	13.9	13.5
Thermal resistance	$R_{th}$	[°C/W]	1.33	
Mechanical time constant (a)	$T_m$	[ms]	0.52	0.54
Rotor inertia without holding brake	$J$	[kg·cm <sup>2</sup> ]	15.18	
Rotor inertia with holding brake	$J$	[kg·cm <sup>2</sup> ]	16.55	
Mass without holding brake	$m$	[kg]	13.68	
Mass with holding brake	$m$	[kg]	17.20	
Max. axial shaft load 2500 rpm	$SL_a$	[N]	450	
Max. radial shaft load 2500 rpm	$SL_r$	[N]	1850	

Rated output with 475 x 475 x 20 mm aluminium heat sink flange coupling. Derating must be considered if the oil seal is applied - IP 54 standard shaft bushing. (\*) without brake. (a) without brake and without feedback.

## TORQUE/SPEED CHARTS

### Operative temperature -20 ÷ +40 °C

Any specifications are subjected to change without notice.  
All rights reserved Motor Power Company®

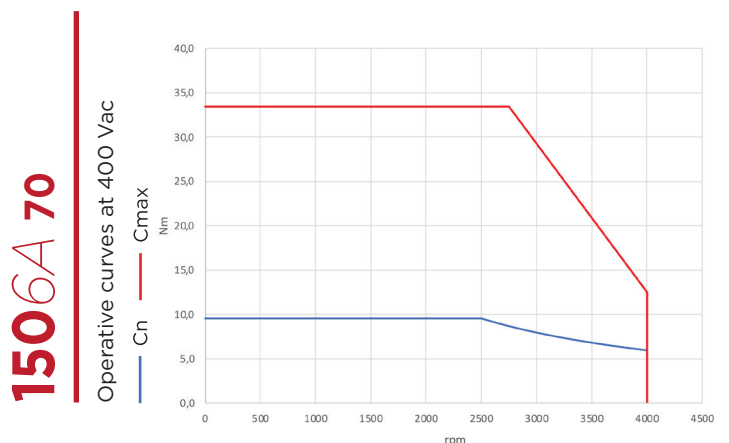
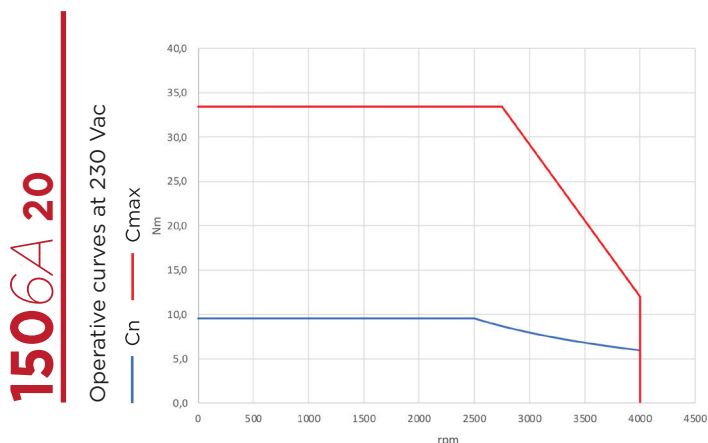

## 150 6B RATINGS and SPECIFICATION

TYPE OF WINDING	230 Vac		400 Vac	
	F1	15	G1	17
<b>ELECTRICAL DATA</b>				
Continuous stall torque (*)	$M_o$	[Nm]	19.10	
Peak torque	$M_{Max}$	[Nm]	66.85	
Nominal torque	$M_n$	[Nm]	12.73	
Nominal power	$P_n$	[W]	4000	
Continuous stall current	$I_o$	[Arms]	23.10	13.12
Maximum current	$I_{Max}$	[Arms]	89.82	51.03
Nominal current	$I_n$	[Arms]	16.56	9.41
Nominal working speed	$n_N$	[rpm]	3000	
Maximum working speed	$n_{Max}$	[rpm]	4000	4000
Torque constant	$K_t$	[Nm/Arms]	0.83	1.46
Voltage constant	$K_{e\ u-v}$	[Vrms/krpm]	50.0	88.0
Winding resistance @ 20 °C	$R_{u-v}$	[Ohm]	0.086	0.282
Winding inductance	$L_{q\ u-v}$	[mH]	1.60	5.090
Electrical time constant	$T_e$	[ms]	18.6	18.0
Thermal resistance	$R_{th}$	[°C/W]	0.90	
Mechanical time constant (a)	$T_m$	[ms]	0.35	0.37
Rotor inertia without holding brake	$J$	[kg·cm <sup>2</sup> ]	27.68	
Rotor inertia with holding brake	$J$	[kg·cm <sup>2</sup> ]	28.76	
Mass without holding brake	$m$	[kg]	18.00	
Mass with holding brake	$m$	[kg]	22.40	
Max. axial shaft load 2500 rpm	$SL_a$	[N]	450	
Max. radial shaft load 2500 rpm	$SL_r$	[N]	1850	

Rated output with 475 x 475 x 20 mm aluminium heat sink flange coupling. Derating must be considered if the oil seal is applied - IP 54 standard shaft bushing. (\*) without brake. (a) without brake and without feedback.

## TORQUE/SPEED CHARTS

### Operative temperature -20 ÷ +40 °C

Any specifications are subjected to change without notice.  
All rights reserved Motor Power Company®

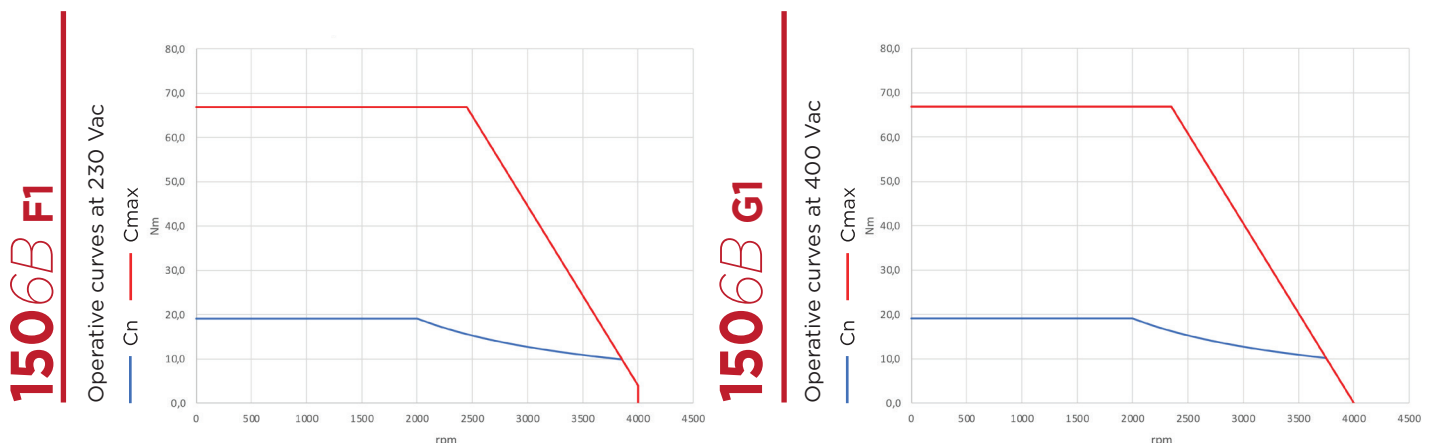

## 150 6C RATINGS and SPECIFICATION

TYPE OF WINDING	230 Vac		400 Vac	
	F1	15	G1	17
<b>ELECTRICAL DATA</b>				
Continuous stall torque (*)	$M_o$	[Nm]	28.65	
Peak torque	$M_{Max}$	[Nm]	100.275	
Nominal torque	$M_n$	[Nm]	19.1	
Nominal power	$P_n$	[W]	6000	
Continuous stall current	$I_o$	[Arms]	34.64	19.68
Maximum current	$I_{Max}$	[Arms]	134.72	76.55
Nominal current	$I_n$	[Arms]	24.84	14.11
Nominal working speed	$n_N$	[rpm]	3000	
Maximum working speed	$n_{Max}$	[rpm]	4000	4000
Torque constant	$K_t$	[Nm/Arms]	0.83	1.46
Voltage constant	$K_{e\ u-v}$	[Vrms/krpm]	50.0	88.0
Winding resistance @ 20 °C	$R_{u-v}$	[Ohm]	0.057	0.171
Winding inductance	$L_{q\ u-v}$	[mH]	1.10	3.320
Electrical time constant	$T_e$	[ms]	19.4	19.4
Thermal resistance	$R_{th}$	[°C/W]	0.61	
Mechanical time constant (a)	$T_m$	[ms]	0.33	0.33
Rotor inertia without holding brake	$J$	[kg·cm <sup>2</sup> ]	40.17	
Rotor inertia with holding brake	$J$	[kg·cm <sup>2</sup> ]	41.25	
Mass without holding brake	$m$	[kg]	23.26	
Mass with holding brake	$m$	[kg]	27.67	
Max. axial shaft load 2500 rpm	$SL_a$	[N]	450	
Max. radial shaft load 2500 rpm	$SL_r$	[N]	1850	

Rated output with 475 x 475 x 20 mm aluminium heat sink flange coupling. Derating must be considered if the oil seal is applied - IP 54 standard shaft bushing. (\*) without brake. (a) without brake and without feedback.

## TORQUE/SPEED CHARTS

### Operative temperature -20 ÷ +40 °C

Any specifications are subjected to change without notice.  
All rights reserved Motor Power Company®

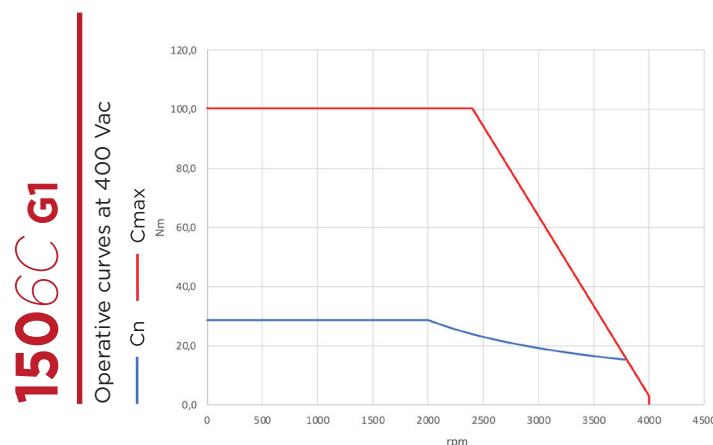
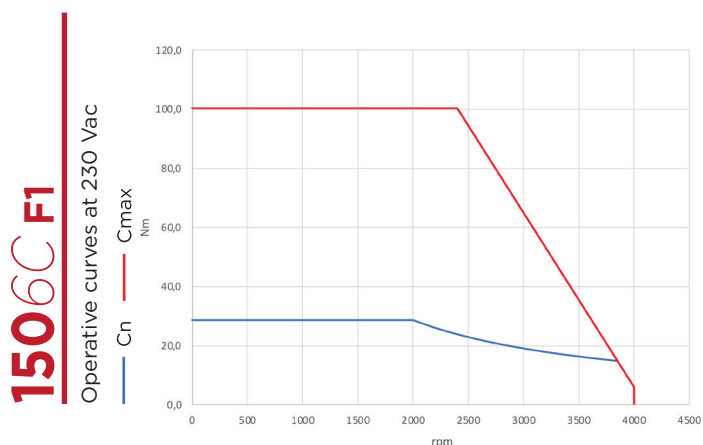

# EXTERNAL DIMENSIONS 150

## G2/H2 connection

Model	Feedback type	L [mm]	L with brake [mm]	Z [mm]	Z with brake [mm]
6A	A1-M1-M2-R1	205.0	250.0	126.5	126.5
6B	A1-M1-M2-R1	250.0	295.0	171.0	171.0
6C	A1-M1-M2-R1	295.0	340.0	216.5	216.5

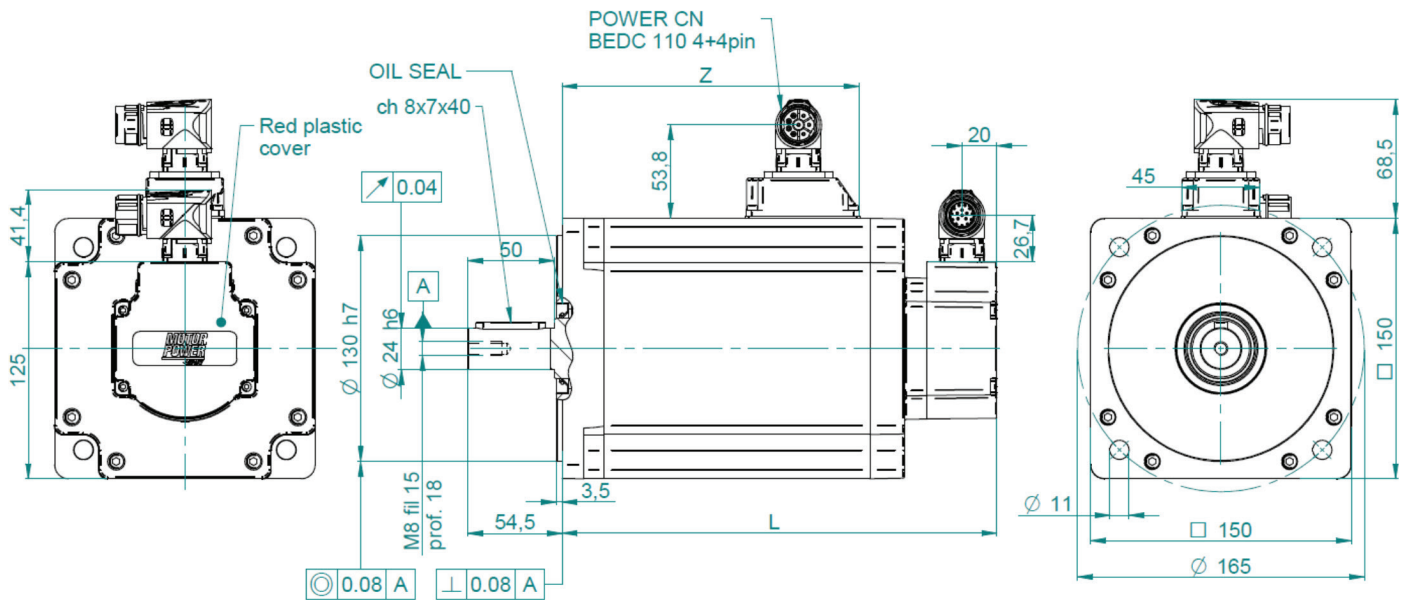







TETRA  
COMPACT



180

## 180 7A RATINGS and SPECIFICATION

	230/400 Vac
TYPE OF WINDING	26

### ELECTRICAL DATA

Continuous stall torque (*)	$M_o$	[Nm]	9.55
Peak torque	$M_{Max}$	[Nm]	28.65
Nominal torque	$M_n$	[Nm]	6.37
Nominal power	$P_n$	[W]	2000
Continuous stall current	$I_o$	[Arms]	8.75
Maximum current	$I_{Max}$	[Arms]	35.5
Nominal current	$I_n$	[Arms]	6.27
Nominal working speed	$n_N$	[rpm]	3000
Maximum working speed	$n_{Max}$	[rpm]	4000
Torque constant	$K_t$	[Nm/Arms]	1.09
Voltage constant	$K_{e\ u-v}$	[Vrms/krpm]	66
Winding resistance @ 20 °C	$R_{u-v}$	[Ohm]	0.590
Winding inductance	$L_{q\ u-v}$	[mH]	6.7
Electrical time constant	$T_e$	[ms]	11.4
Thermal resistance	$R_{th}$	[°C/W]	-
Mechanical time constant (a)	$T_m$	[ms]	1.25
Rotor inertia without holding brake	$J$	[kg·cm <sup>2</sup> ]	25.22
Rotor inertia with holding brake	$J$	[kg·cm <sup>2</sup> ]	30.39
Mass without holding brake	$m$	[kg]	14.64
Mass with holding brake	$m$	[kg]	19.64
Max. axial shaft load 3000 / 6000 rpm	$SL_a$	[N]	500
Max. radial shaft load 3000 / 6000 rpm	$SL_r$	[N]	2300

Rated output with 550 x 550 x 20 mm aluminium heat sink flange. Derating must be considered if the oil seal is applied - IP 54 standard shaft bushing.  
 (\*) without brake. (a) without brake and without feedback.

## TORQUE/SPEED CHARTS

### Operative temperature -20 ÷ +40 °C

Any specifications are subjected to change without notice.  
 All rights reserved Motor Power Company®

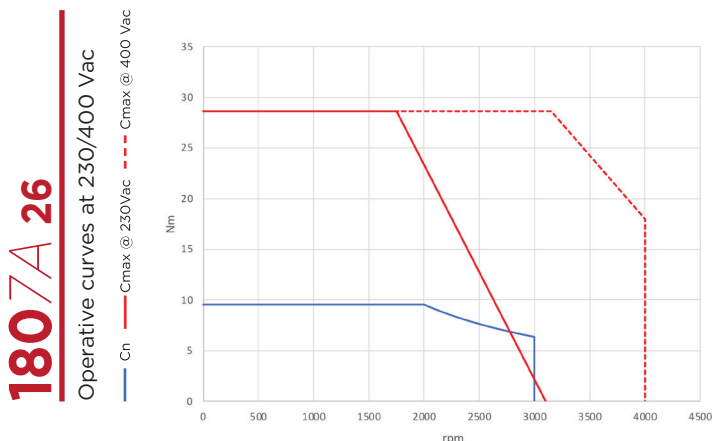

## 180 7C RATINGS and SPECIFICATION

	TYPE OF WINDING	230/400 Vac		
		15A		
<b>ELECTRICAL DATA</b>				
Continuous stall torque (*)	$M_o$	[Nm]	16.7	
Peak torque	$M_{Max}$	[Nm]	50.3	
Nominal torque	$M_n$	[Nm]	11.14	
Nominal power	$P_n$	[W]	3500	
Continuous stall current	$I_o$	[Arms]	16.83	
Maximum current	$I_{Max}$	[Arms]	61.0	
Nominal current	$I_n$	[Arms]	12.07	
Nominal working speed	$n_N$	[rpm]	3000	
Maximum working speed	$n_{Max}$	[rpm]	4000	
Torque constant	$K_t$	[Nm/Arms]	0.99	
Voltage constant	$K_{e\ u-v}$	[Vrms/krpm]	60	
Winding resistance @ 20 °C	$R_{u-v}$	[Ohm]	0.136	
Winding inductance	$L_{q\ u-v}$	[mH]	2.48	
Electrical time constant	$T_e$	[ms]	18.2	
Thermal resistance	$R_{th}$	[°C/W]	-	
Mechanical time constant (e)	$T_m$	[ms]	TBD	TBD
Rotor inertia without holding brake	$J$	[kg·cm <sup>2</sup> ]	TBD	
Rotor inertia with holding brake	$J$	[kg·cm <sup>2</sup> ]	TBD	
Mass without holding brake	$m$	[kg]	TBD	
Mass with holding brake	$m$	[kg]	TBD	
Max. axial shaft load 3000 / 6000 rpm	$SL_a$	[N]	500	
Max. radial shaft load 3000 / 6000 rpm	$SL_r$	[N]	2300	

Rated output with 550 x 550 x 20 mm aluminium heat sink flange. Derating must be considered if the oil seal is applied - IP 54 standard shaft bushing.  
 (\*) without brake. (a) without brake and without feedback.

## TORQUE/SPEED CHARTS

### Operative temperature -20 ÷ +40 °C

Any specifications are subjected to change without notice.  
 All rights reserved Motor Power Company®

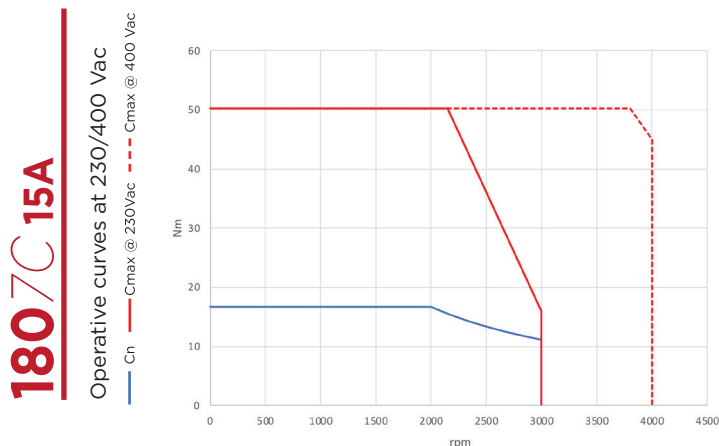

## 180 7D RATINGS and SPECIFICATION

	TYPE OF WINDING	230/400 Vac	
		G1	
<b>ELECTRICAL DATA</b>			
Continuous stall torque (*)	$M_o$	[Nm]	28.65
Peak torque	$M_{Max}$	[Nm]	71.62
Nominal torque	$M_n$	[Nm]	28.65
Nominal power	$P_n$	[W]	4500
Continuous stall current	$I_o$	[Arms]	19.68
Maximum current	$I_{Max}$	[Arms]	61.0
Nominal current	$I_n$	[Arms]	22.8
Nominal working speed	$n_N$	[rpm]	1500
Maximum working speed	$n_{Max}$	[rpm]	4000
Torque constant	$K_t$	[Nm/Arms]	1.46
Voltage constant	$K_{e\ u-v}$	[Vrms/krpm]	88
Winding resistance @ 20 °C	$R_{u-v}$	[Ohm]	0.169
Winding inductance	$L_{q\ u-v}$	[mH]	3.46
Electrical time constant	$T_e$	[ms]	20.4
Thermal resistance	$R_{th}$	[°C/W]	-
Mechanical time constant (a)	$T_m$	[ms]	TBD
Rotor inertia without holding brake	$J$	[kg·cm <sup>2</sup> ]	TBD
Rotor inertia with holding brake	$J$	[kg·cm <sup>2</sup> ]	TBD
Mass without holding brake	$m$	[kg]	TBD
Mass with holding brake	$m$	[kg]	TBD
Max. axial shaft load 3000 / 6000 rpm	$SL_a$	[N]	500
Max. radial shaft load 3000 / 6000 rpm	$SL_r$	[N]	2300

Rated output with 550 x 550 x 20 mm aluminium heat sink flange. Derating must be considered if the oil seal is applied - IP 54 standard shaft bushing.  
 (\*) without brake. (a) without brake and without feedback.

## TORQUE/SPEED CHARTS

### Operative temperature -20 ÷ +40 °C

Any specifications are subjected to change without notice.  
 All rights reserved Motor Power Company®

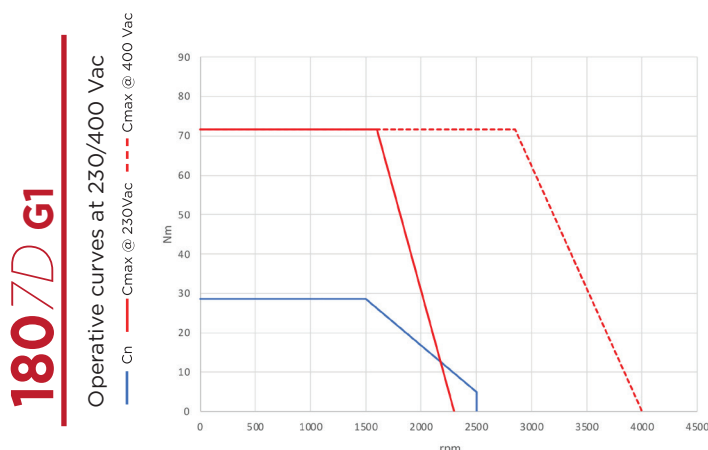

## 180 7E RATINGS and SPECIFICATION

	TYPE OF WINDING	230/400 Vac	
		G5	
<b>ELECTRICAL DATA</b>			
Continuous stall torque (*)	$M_o$	[Nm]	35
Peak torque	$M_{Max}$	[Nm]	87.53
Nominal torque	$M_n$	[Nm]	35
Nominal power	$P_n$	[W]	5500
Continuous stall current	$I_o$	[Arms]	25.05
Maximum current	$I_{Max}$	[Arms]	74.2
Nominal current	$I_n$	[Arms]	28.8
Nominal working speed	$n_N$	[rpm]	1500
Maximum working speed	$n_{Max}$	[rpm]	4000
Torque constant	$K_t$	[Nm/Arms]	1.4
Voltage constant	$K_{e\ u-v}$	[Vrms/krpm]	84.5
Winding resistance @ 20 °C	$R_{u-v}$	[Ohm]	0.093
Winding inductance	$L_{q\ u-v}$	[mH]	2.08
Electrical time constant	$Te$	[ms]	22.4
Thermal resistance	$R_{th}$	[°C/W]	-
Mechanical time constant (a)	$T_m$	[ms]	TBD
Rotor inertia without holding brake	$J$	[kg·cm <sup>2</sup> ]	TBD
Rotor inertia with holding brake	$J$	[kg·cm <sup>2</sup> ]	TBD
Mass without holding brake	$m$	[kg]	TBD
Mass with holding brake	$m$	[kg]	TBD
Max. axial shaft load 3000 / 6000 rpm	$SL_a$	[N]	500
Max. radial shaft load 3000 / 6000 rpm	$SL_r$	[N]	2300

Rated output with 550 x 550 x 20 mm aluminium heat sink flange. Derating must be considered if the oil seal is applied - IP 54 standard shaft bushing.  
 (\*) without brake. (a) without brake and without feedback.

## TORQUE/SPEED CHARTS

### Operative temperature -20 ÷ +40 °C

Any specifications are subjected to change without notice.  
 All rights reserved Motor Power Company®

**180 7E G5**  
 Operative curves at 230/400 Vac  
 —  $C_n$  —  $C_{max@230Vac}$  - - -  $C_{max@400Vac}$

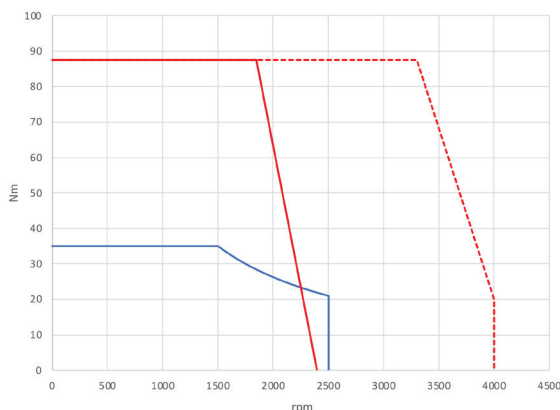

## 180 7F RATINGS and SPECIFICATION

	230/400 Vac	
TYPE OF WINDING	69	

### ELECTRICAL DATA

Continuous stall torque (*)	$M_0$	[Nm]	47.75	
Peak torque	$M_{Max}$	[Nm]	119.37	
Nominal torque	$M_n$	[Nm]	47.75	
Nominal power	$P_n$	[W]	7500	
Continuous stall current	$I_0$	[Arms]	36.08	
Maximum current	$I_{Max}$	[Arms]	106.9	
Nominal current	$I_n$	[Arms]	41.5	
Nominal working speed	$n_N$	[rpm]	1500	
Maximum working speed	$n_{Max}$	[rpm]	4000	
Torque constant	$K_t$	[Nm/Arms]	1.32	
Voltage constant	$K_{e\ u-v}$	[Vrms/krpm]	80	
Winding resistance @ 20 °C	$R_{u-v}$	[Ohm]	0.053	
Winding inductance	$L_{q\ u-v}$	[mH]	1.34	
Electrical time constant	$T_e$	[ms]	25.3	
Thermal resistance	$R_{th}$	[°C/W]	-	
Mechanical time constant (a)	$T_m$	[ms]	TBD	TBD
Rotor inertia without holding brake	$J$	[kg·cm <sup>2</sup> ]	TBD	
Rotor inertia with holding brake	$J$	[kg·cm <sup>2</sup> ]	TBD	
Mass without holding brake	$m$	[kg]	TBD	
Mass with holding brake	$m$	[kg]	TBD	
Max. axial shaft load 3000 / 6000 rpm	$SL_a$	[N]	500	
Max. radial shaft load 3000 / 6000 rpm	$SL_r$	[N]	2300	

Rated output with 550 x 550 x 20 mm aluminium heat sink flange. Derating must be considered if the oil seal is applied - IP 54 standard shaft bushing.  
 (\*) without brake. (a) without brake and without feedback.

## TORQUE/SPEED CHARTS

### Operative temperature -20 ÷ +40 °C

Any specifications are subjected to change without notice.  
 All rights reserved Motor Power Company®

**180 7F 69**  
 Operative curves at 230/400 Vac  
 —  $C_n$  —  $C_{max}$  @ 230Vac —  $C_{max}$  @ 400 Vac

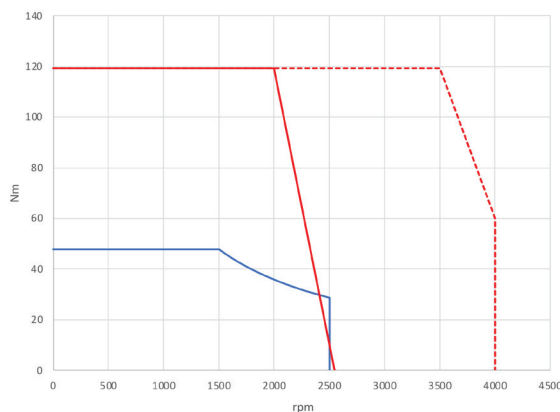



## G2/H2 connection

Model	Feedback type	L [mm]	L with brake [mm]	Z [mm]	Z with brake [mm]
7A	A1-M1-M2-R1	183.0	230.0	103.0	103.0
7C	A1-M1-M2-R1	225.0	260.0	145.0	145.0
7D	A1-M1-M2-R1	255.0	290.0	175.0	175.0
7E	A1-M1-M2-R1	305.0	340.0	225.0	225.0
7F	A1-M1-M2-R1	360.0	391.0	276.0	276.0

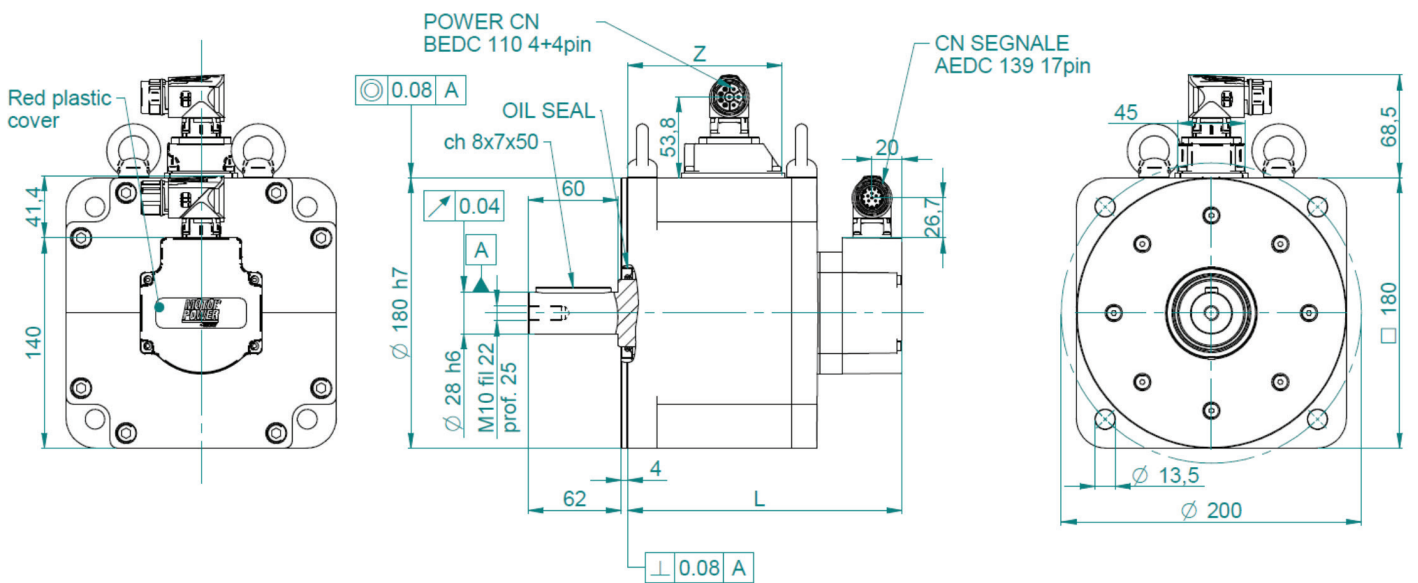



# feedback

## TC4 Resolver

		R1	
<i>Motor size</i>		TC4 60 - TC4 80	TC4 100 - TC4 130 - TC4 150 - TC4 180
Nominal voltage	Vrms	7±5%	7±5%
Nominal current	mA	50	50
Phase shift		+3°	-5°
Minimum sin amplitude	mVrms	20	20
Frequency	kHz	10	10
Poles number		2	2
Tranformer ratio		0.5 ± 5%	0.5 ± 5%
Input impedance	Ohm	130 + j280	110+j140
Output impedance	Ohm	425 + j755	130+j240
System accuracy		± 10'	± 10'
Rotor inertia	kg cm2	0.03	0.1

# TC4 Encoder

	<b>M1</b>	<b>M2</b>	<b>M3</b>
<i>Type</i>	<b>M-CODER IH INCREMENTAL WITH HALL SENSOR ENCODER</b>	<b>M-CODER ST ABSOLUTE ENCODER</b>	<b>M-CODER STBL ABSOLUTE ENCODER</b>
Protocol/Interface	Line Driver A/B/Z - U/V/W	RS 485 2,5 Mbit	Biss Line 2 Wire
Resolution	2-5000 ppr	23 bit	23 bit
Accuracy	+/- 250''	+/- 250''	+/- 250''
Working temperature	-40 °C ... +125 °C	-40 °C ... +125 °C	-40 °C ... +125 °C
Working speed	<12000 rpm	<12000 rpm	<12000 rpm
Max acceleration	100.000 rad/s <sup>2</sup>	100.000 rad/s <sup>2</sup>	100.000 rad/s <sup>2</sup>
Inertia	5.6 × 10 <sup>-5</sup> kg*cm <sup>2</sup>	5.6 × 10 <sup>-5</sup> kg*cm <sup>2</sup>	5.6 × 10 <sup>-5</sup> kg*cm <sup>2</sup>
Weigth	20 g	20 g	20 g
Main supply voltage	<b>5 - 12 V</b>	5 - 12 V	5 - 12 V
Current consumption	100mA (Max)	100mA (Max)	100mA (Max)
External battery voltage	-	-	-
External battery current consumption	-	-	-
Note	Condition monitoring option	Condition monitoring option	Condition monitoring option

	<b>A5</b>	<b>A6</b>	<b>A15</b>
<i>Type</i>	<b>HIPERFACE SAFETY DSL SINGLETURN 20 BIT ENCODER</b>	<b>HIPERFACE SAFETY DSL MULTITURN 20 BIT ENCODER</b>	<b>HIPERFACE SAFETY DSL SINGLETURN 24 BIT ENCODER</b>
Protocol/Interface	HIPERFACE DSL®	HIPERFACE DSL®	HIPERFACE DSL®
Resolution	20 bit	20 bit	24 bit
N° absolute multiturn steps	-	4096 (12 bit)	-
Accuracy	+/- 100''	+/- 100''	+/- 25''
Working temperature	-20 °C ... +115 °C	-20 °C ... +115 °C	-40 °C ... +115 °C
Working speed	<12000 rpm	<12000 rpm	<9000 rpm
Max acceleration	250.000 rad/s <sup>2</sup>	250.000 rad/s <sup>2</sup>	250.000 rad/s <sup>2</sup>
Inertia	5 gcm <sup>2</sup>	5 gcm <sup>2</sup>	5 gcm <sup>2</sup>
Weigth	100 g	100 g	100 g
Main supply voltage	<b>7 - 12 V</b>	7 - 12 V	7 - 12 V
Current consumption	150 mA (max)	150 mA (max)	150 mA (max)
External battery voltage	-	-	-
External battery current consumption	-	-	-
Note		Mechanical multiturn	

Safety function: SIL2 (IEC 61508) PL.d (EN ISO 13849)

Safety function: SIL2 (IEC 61508) PL.d (EN ISO 13849)

Safety function: SIL2 (IEC 61508) PL.d (EN ISO 13849-1:2015)

<i>Type</i>	A1	A3	A4
	HIPERFACE ABSOLUTE MULTITURN ENCODER	HIPERFACE DSL ABSOLUTE SINGLETURN ENCODER	HIPERFACE DSL ABSOLUTE MULTITURN ENCODER
Protocol/Interface	HIPERFACE®	HIPERFACE DSL®	HIPERFACE DSL®
Resolution	128 line	20 bit	20 bit
N° absolute multiturn steps	<b>4096 (12 bit)</b>	-	4096 (12 bit)
Accuracy	4096 (12 bit)	+/- 100''	+/- 100''
Working temperature	-20 °C ... +100 °C	-20 °C ... +115 °C	-20 °C ... +115 °C
Working speed	<9000 rpm	<12000 rpm	<12000 rpm
Max acceleration	500.000 rad/s <sup>2</sup>	500.000 rad/s <sup>2</sup>	500.000 rad/s <sup>2</sup>
Inertia	4,5 gcm <sup>2</sup>	4,5 gcm <sup>2</sup>	4,5 gcm <sup>2</sup>
Weigth	70 g	100 g	100 g
Main supply voltage	<b>7 - 12 V</b>	7 - 12 V	7 - 12 V
Current consumption	60 mA (withoul Load)	150 mA (max)	150 mA (max)
External battery voltage	-	-	-
External battery current consumption	-	-	-
Note	Mechanical multiturn		Mechanical multiturn

<i>Type</i>	A16	A22	A23
	HIPERFACE SAFETY DSL MULTITURN 24 BIT ENCODER	ENCODER SAFETY ENDAT 3 SINGLETURN 19 BIT ENCODER	ENCODER SAFETY ENDAT 3 MULTITURN 19 BIT ENCODER
Protocol/Interface	HIPERFACE DSL®	ENDAT 3®	ENDAT 3®
Resolution	24 bit	19 bit	19 bit
N° absolute multiturn steps	<b>4096 (12 bit)</b>	-	4096 (12 bit)
Accuracy	+/- 25''	+/- 120''	+/- 120''
Working temperature	-40 °C ... +115 °C	-40 °C ... +110 °C	-40 °C ... +110 °C
Working speed	<9000 rpm	<15000 rpm	<12000 rpm
Max acceleration	250.000 rad/s <sup>2</sup>	≤ 1 · 10 <sup>5</sup> rad/s <sup>2</sup>	≤ 1 · 10 <sup>5</sup> rad/s <sup>2</sup>
Inertia	5 gcm <sup>2</sup>	0.2 · 10 <sup>-6</sup> kgm <sup>2</sup>	0.2 · 10 <sup>-6</sup> kg m <sup>2</sup>
Weigth	100 g	40 g	40 g
Main supply voltage	<b>7 - 12 V</b>	3,6 - 14 V	3,6 - 14 V
Current consumption	150 mA (max)	At 5 V: 95 mA (without load)	At 5 V: 115 mA (without load)
External battery voltage	-	-	-
External battery current consumption	-	-	-
Note	Mechanical multiturn		Mechanical multiturn

Safety function: SIL2 (IEC 61508) PLd (EN ISO 13849-1:2015)

Safety function: SIL3 (IEC 61508) PLe

Safety function: SIL3 (IEC 61508) PLe

# TC4 Encoder

**N1**

**Type** **A-format 24-bit absolute multi-turn (with battery) and absolute single turn encoder (without battery). Encoder N1 available for models 40-60-80**

Protocol/Interface	A-FORMAT RS 485 2,5-16Mbits
Resolution	24 bit
N° absolute multiturn steps	<b>65536 (16 bit)</b>
Accuracy	+/- 90"
Working temperature	-20 °C ... +105 °C
Working speed	<8000 rpm
Max acceleration	$1.0 \times 10^5 \text{ rad/s}^2$
Inertia	$2.6 \times 10^{-9} \text{ kg} \cdot \text{m}^2$
Weigth	13 g
Main supply voltage	<b>5 +/- 10% V</b>
Current consumption	80uA typical 110 uA max
External battery voltage	3,6 +/-10% V
External battery current consumption	55uA typical 110 uA max

Note Feedback N1 is provided as singleturn device.  
With the multiturn usage battery must be applied. Please reach out our application team for assistance with the electric scheme connection.

# specifications

## TC4 Brake features

MOTOR SIZE		40	60	80	100	130	150	180
Operating motor temperature	[°C]	-20 ÷ 120						
External ambient temperature	[°C]	-20 ÷ 40						
Standard brake duty	-	Stationary						
Minimum dry static torque (-20 ÷ 120 °C)	[Nm]	0.32	1.3	2.5	6.5	9.6	32	48
Nominal operating voltage (± 10 %)	[Vdc]	24						
Power consumption at 20 °C (± 7 %)	[W]	4.35	11.2	10.2	10.4	19.7	TBD	49.6
Release time	[ms]	22	58	46	49	71	TBD	120
Brake release time (pull-in)	[ms]	77	25	58	30	39	TBD	37
Maximum backlash	[deg]	1.2						

# TC4 Wiring motor connection

## Connectors with G2 connection

Power connector		Feedback connector			
Pin	Function	Pin	A1	N1	R1
1	Phase U	1	-	-	-
2	PE	2	-	-	-
3	Phase W	3	0V	0V	-
4	Phase V	4	7-12V	+ 5V	-
A	Brake + (#)	5	/sin	data -	/sin
B	Brake - (#)	6	sin	data +	sin
C	PT 1000 +	7	/data	-	/ref
D	PT 1000 -	8	data	-	ref
		9	-	-	-
		10	shield	shield	shield
		11	/cos	-	/cos
		12	cos	-	cos
		13	-	-	-
		14	-	-	-
		15	-	-	-
		16	-	-	-
		17	-	-	-

(#) Optional

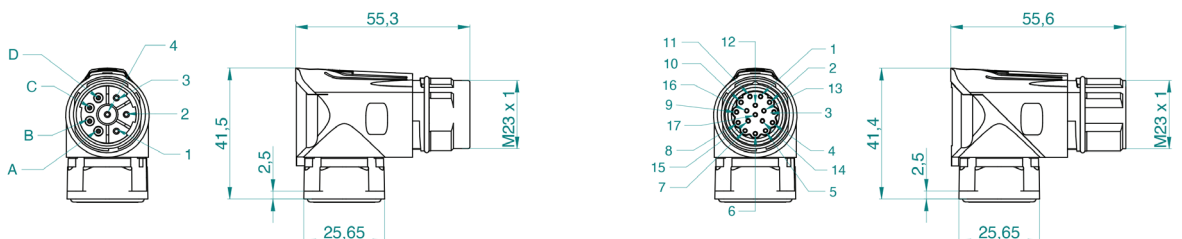



# Wiring motor connection **TC4**

## Connectors with H2 connection

Power connector		Feedback connector			
Pin	Function	Pin	A1	N1	R1
1	Phase U	1	-	-	-
2	PE	2	-	-	-
3	Phase W	3	0V	0V	-
4	Phase V	4	7-12V	+ 5V	-
A	Brake + (#)	5	/sin	data -	/sin
B	Brake - (#)	6	sin	data +	sin
C	-	7	/data	-	/ref
D	-	8	data	-	ref
		9	-	-	-
		10	shield	shield	shield
		11	/cos	-	/cos
		12	cos	-	cos
		13	-	-	-
		14	-	-	-
		15	-	-	-
		16	PT 1000 +	PT 1000 +	PT 1000 +
		17	PT 1000 -	PT 1000 -	PT 1000 -

(#) Optional

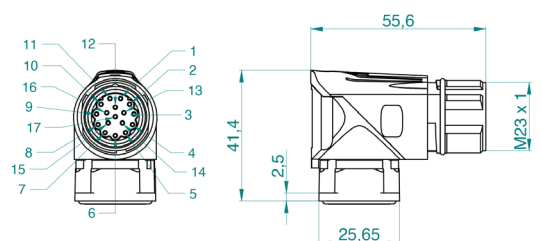
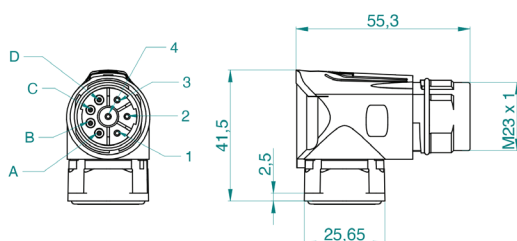

# TC4 Wiring motor connection

## Connectors with D0 connection (only for models 40-60-80)

Power connector		Feedback connector			
Pin	Function	Pin	A1	N1	R1
1	Phase U	1	data +	data +	-
2	Phase V	2	+ sin	data -	-
3	Phase W	3	Refsin	-	-
4	PE	4	data -	-	-
5	PT 1000 + / brake + <sup>(#)</sup>	5	+ cos	-	-
6	PT 1000 - / brake - <sup>(#)</sup>	6	Refcos	-	-
		7	8V / us	+ 5V	-
		8	0V	0V	-
		9	shield	shield	-

(#) Optional



Motor Power Company  
[www.motorpowerco.com](http://www.motorpowerco.com)  
[info@motorpowerco.it](mailto:info@motorpowerco.it)

All rights reserved.  
Complete or partial reproduction  
is not allowed without our permission.

All technical data in this catalog  
may be changed without prior notice.



**Motor Power  
Company s.r.l.**

Via Leonardo Da Vinci, 4  
42024 Castelnovo Sotto  
Reggio Emilia (Italy)  
Tel. +39 0522 682710  
Fax +39 0522 683552  
info@motorpowerco.it

**Motor Power Company  
(Taicang) Motion Co. Ltd.**

Workshop 7, Shiny Science Park No. 111  
215400 Taicang, P.R.China  
Tel + 86 512 33337978  
Fax +86 512 53207871  
infoasia@motorpowerco.com



**motorpowerco.com**

